

TC4

TETRA COMPACT 4

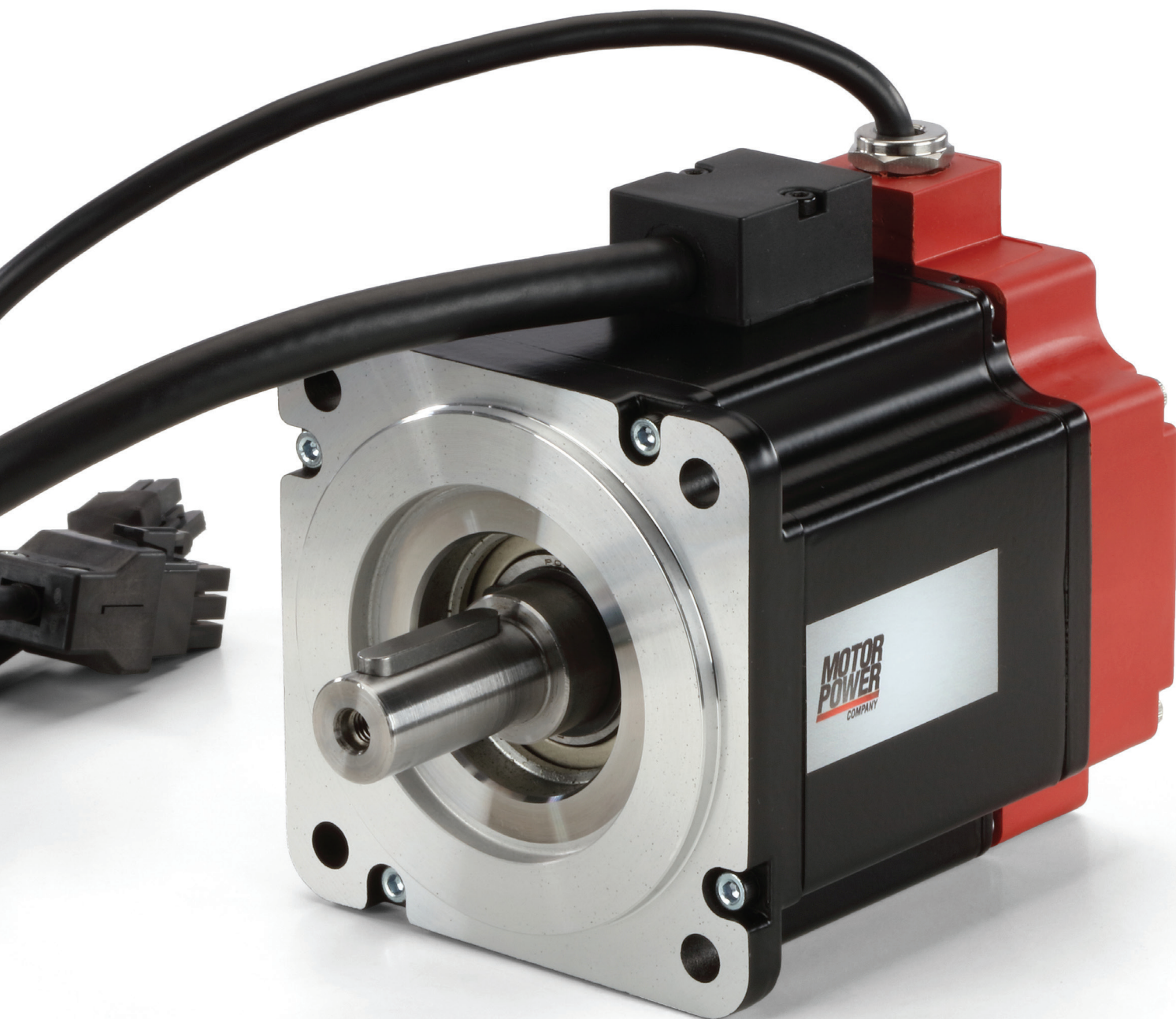

SEE IT BEFORE IT HAPPENS

**MOTOR
POWER**
COMPANY

TETRA COMPACT 4

NEXT-LEVEL SERVO MOTORS

Introducing the TETRA COMPACT 4 series from Motor Power Company a breakthrough in high-performance brushless servo motors. Born from years of hands-on experience, these motors redefine the standards in the brushless servomotors category.

With a unique design that is 30% shorter than its predecessors, the TETRA COMPACT 4 series maintains exceptional power density, efficiency, and speed, setting a new benchmark for AC synchronous motors.

This series features 10-pole servomotors with a variety of feedback options, offering unmatched quality and a broad range of power ratings. Perfectly suited for modern machine performance requirements, Motor Power Company doesn't just provide individual components but complete motion solutions. Pairing these high-performance servomotors with versatile drives of the series BL servo, the TETRA COMPACT 4 series excels across a diverse array of applications. Welcome to a new era of innovation and efficiency in motion technology.

CONTENTS

	Features	5
	Servomotor type designation	6
	Winding table code	7
	Product lineup	8
TC4 40 1A	Ratings and Specifications - Torque /Speed charts	10
TC4 40 1B	Ratings and Specifications - Torque /Speed charts	12
	External dimensions	14
TC4 60 2A	Ratings and Specifications - Torque /Speed charts	16
TC4 60 2B	Ratings and Specifications - Torque /Speed charts	18
	External dimensions	20
TC4 80 3A	Ratings and Specifications - Torque /Speed charts	22
TC4 80 3B	Ratings and Specifications - Torque /Speed charts	24
TC4 80 3C	Ratings and Specifications - Torque /Speed charts	26
	External dimensions	28
TC4 100 4A	Ratings and Specifications - Torque /Speed charts	30
TC4 100 4B	Ratings and Specifications - Torque /Speed charts	32
	External dimensions	34
TC4 130 5F	Ratings and Specifications - Torque /Speed charts	36
TC4 130 5G	Ratings and Specifications - Torque /Speed charts	37
TC4 130 5H	Ratings and Specifications - Torque /Speed charts	38
	External dimensions	39
TC4 150 6A	Ratings and Specifications - Torque /Speed charts	42
TC4 150 6B	Ratings and Specifications - Torque /Speed charts	43
TC4 150 6C	Ratings and Specifications - Torque /Speed charts	44
	External dimensions	45
TC4 180 7A	Ratings and Specifications - Torque /Speed charts	48
TC4 180 7C	Ratings and Specifications - Torque /Speed charts	49
TC4 180 7D	Ratings and Specifications - Torque /Speed charts	50
TC4 180 7E	Ratings and Specifications - Torque /Speed charts	51
TC4 180 7F	Ratings and Specifications - Torque /Speed charts	52
	External dimensions	53
	Feedback Resolver	55
	Feedback Encoder	56
	Brake features	59
	Wiring motor connection	60



UL file: E216686 - MPC IF 155

FEATURES

Motor type	Three-phase BPM synchronous servo motor
POLES Number	10 (5 poles pair)
Available frame sizes	40 - 60 - 80 - 100 - 130 - 150 - 180 mm
Rated output torque	From 0.16 to 47.75 Nm
Rated output power	From 50 to 7500 W
Rated servomotor speed	Up to 6000 rpm
Maximum servomotor speed	Up to 8000 rpm
Insulation class	F (155 °C)
Protection class	IP 65 (with oil seal)
Ambient operating temperature	-20 ÷ +40 °C
Ambient storage temperature	-40 ÷ +70 °C
Relative humidity	5 ÷ 85 %, non-condensing
Cooling type	Natural convective
Maximum operating altitude	Up to 3000 m above sea level (derating 1%/100m from 1000 onwards)
Temperature sensor	PT1000 (no sensor for size 40)
Shaft end	Smooth or keyed
Feedback	Resolver, TTL Encoder, Absolute Encoder (Hiperface, EnDat, BiSS Line, RS-485)*
Bearing life	20.000 h under rated operation condition
Balancing quality grade	G 6.3 according to ISO 1940
Magnet material	NdFeB with epoxy coating
External coating	RAL 9005 black powder
Approvals	CE, Rohs, Reach, UL file: E216686 - MPC IF 155

*Available also in single cable configuration

TC4 SERVOMOTOR TYPE DESIGNATION

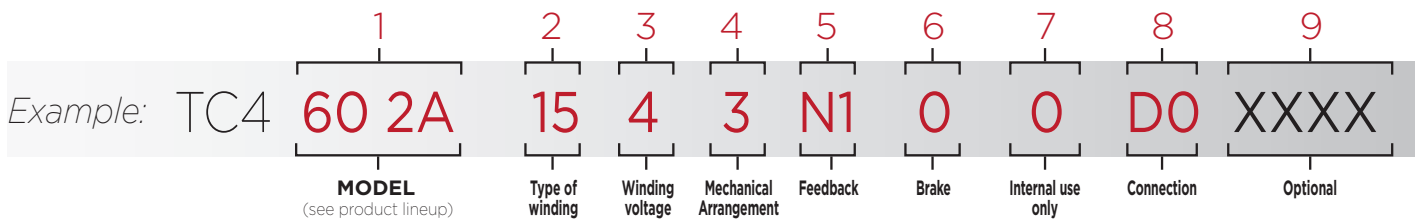

1	MODEL	See PRODUCT LINEUP (p.8)
2	TYPE OF WINDING	See WINDING TABLE CODE (p.7)
3	WINDING VOLTAGE	0 → 24 Vdc 1 → 48 Vdc 6 → 60 Vdc 2 → 230 Vac 4 → 400 Vac
4	MECHANICAL ARRANGEMENT	0 Smooth shaft 1 Smooth shaft + oil seal 2 Keyed shaft 3 Keyed shaft + oil seal
5	FEEDBACK	A1* Hiperface absolute multi-turn encoder A3* Hiperface DSL absolute single-turn 20 bit encoder A4* Hiperface DSL absolute multi-turn 20 bit encoder A5* Hiperface safety DSL single-turn 20 bit encoder A6* Hiperface safety DSL multi-turn 20 bit encoder A15* Hiperface safety DSL single-turn 24 bit encoder A16* Hiperface safety DSL multi-turn 24 bit encoder A22* Safety EnDat 3 single-turn 19 bit encoder A23* Safety EnDat 3 multi-turn 19 bit encoder M1 TTL 2000 ppr encoder M2 Absolute single-turn 23 bit RS-485 encoder M3 Absolute single-turn 23 bit BiSS Line encoder N1 A-format 24-bit absolute multi-turn with external battery (not included). Encoder N1 available for models 40-60-80 R1* Resolver

*Not available for TC4 40 models

6	BRAKE	0 Without brake 1 With brake
7	INTERNAL USE ONLY	0 Without PWB 1 With PWB
8	CONNECTION	DO 300mm cable length with 6 pins power AMP connector and 9 pins signal AMP connector, only for sizes 40-60-80 D2 300mm cable length with 6 pins power AMP connector and 15 pins signal AMP connector. This connection is available only for sizes 40-60-80 with M1 encoder. G2 90° M23 turnable connectors - PT 1000 on power connector H2 90° M23 turnable connectors - PT 1000 on signal connector C21 One cable solution 90° M23 turnable connector



WINDING TABLE CODE

		TYPE OF WINDING																									
		9	13	15	15A	16	20	21	22	26	33	41	69	70	77	78	D1	D5	D6	F1	F2	G1	G5	H1	H3	L1	17
SERVOMOTOR TYPE	TC4 40 1A	2									1	0			0	1											
	TC4 40 1B		2								1	0			0	1											
	TC4 60 2A			4		4	2	2																			
	TC4 60 2B			4		4	2	2																			
	TC4 80 3A			4		4	2	2																			
	TC4 80 3B			4		4	2	2																			
	TC4 80 3C			4		4	2	2																			
	TC4 100 4A			2													2		4								4
	TC4 100 4B			2														2							4		4
	TC4 130 5F																				2/4						
	TC4 130 5G																								2/4		
	TC4 130 5H								2/4																		
	TC4 150 6A			2			2							4													4
	TC4 150 6B			2																	2		4				4
	TC4 150 6C			2																	2		4				4
	TC4 180 7A									2/4																	
	TC4 180 7C				2/4																						
	TC4 180 7D																							2/4			
TC4 180 7E																								2/4			
TC4 180 7F													2/4														

PRODUCT LINEUP

Servomotor Type	Nominal Power P_n <small>(ref. to 3000 rpm)</small>	Nominal Power P_n <small>(ref. to 6000 rpm)</small>	Nominal Torque M_n <small>(ref. to 3000 rpm)</small>	Peak Torque M_{max}	Continuous Working Speed n_M	Maximum Working Speed n_{Max}	Moment of Inertia	24 Vdc	48 Vdc	230 Vac	400 Vac
	[W]	[W]	[Nm]	[Nm]	[rpm]	[rpm]	[kg cm ²]				
TC4 40 1A	50	85	0.16	0.56	3000/6000	8000	0.0305	√	√	√	√
TC4 40 1B	100	175	0.32	1.12	3000/6000	8000	0.0561	√	√	√	√
TC4 60 2A	200	350	0.64	2.24	3000/6000	8000	0.223			√	√
TC4 60 2B	400	600	1.27	4.44	3000/6000	8000	0.414			√	√
TC4 80 3A	400	700	1.27	4.44	3000/6000	8000	0.79			√	√
TC4 80 3B	750	1100	2.38	8.33	3000/6000	8000	1.42			√	√
TC4 80 3C	1000	1300	3.18	11.10	3000/6000	8000	2.03			√	√
TC4 100 4A	1000	-	3.18	16.50	3000	6000	2.53			√	√
TC4 100 4B	2000	-	6.37	33.00	3000	6000	4.61			√	√
TC4 130 5F	1000	-	3.18	14.30	3000	4000	6.70			√	√
TC4 130 5G	1500	-	4.77	21.48	3000	4000	9.72			√	√
TC4 130 5H	2000	-	6.36	28.65	3000	4000	12.77			√	√
TC4 150 6A	2500	-	7.95	33.42	3000	4000	15.18			√	√
TC4 150 6B	4000	-	12.73	66.85	3000	4000	27.68			√	√
TC4 150 6C	6000	-	19.10	100.27	3000	4000	40.17			√	√
TC4 180 7A	2000	-	6.37	28.65	3000	4000	25.22			√	√
TC4 180 7C	3500	-	11.14	50.30	3000	4000	-			√	√
TC4 180 7D	4500	-	28.65	71.62	1500	4000	-			√	√
TC4 180 7E	5500	-	35.00	87.53	1500	4000	-			√	√
TC4 180 7F	7500	-	47.75	119.37	1500	4000	-			√	√

WWW
P

TETRA
COMPACT



RATINGS and SPECIFICATION

			24 Vdc		48 Vdc		230 Vac	
TYPE OF WINDING			77	41	78	33	09	09
ELECTRICAL DATA								
Continuous stall torque (*)	M_o	[Nm]			0.18			
Peak torque	M_{Max}	[Nm]			0.56			
Nominal torque	M_n	[Nm]	0.16	0.135	0.16	0.135	0.16	0.135
Nominal power	P_n	[W]	50	85	50	85	50	85
Continuous stall current	I_o	[Arms]	4.35	7.26	2.18	2.72	0.60	0.6
Maximum current	I_{Max}	[Arms]	15.05	25.08	7.52	9.40	2.09	2.09
Nominal current	I_n	[Arms]	3.99	5.61	1.99	2.10	0.55	0.47
Nominal working speed	n_N	[rpm]	3000	6000	3000	6000	3000	6000
Maximum working speed	n_{Max}	[rpm]	6250	8000	6250	8000	8000	8000
Torque constant	K_t	[Nm/Arms]	0.041	0.025	0.083	0.066	0.298	0.298
Voltage constant	$K_{e\ u-v}$	[Vrms/krpm]	2.5	1.5	5.0	4.0	18.0	18.0
Winding resistance @ 20 °C	R_{u-v}	[Ohm]	0.556	0.183	2.235	1.408	27.712	27.712
Winding inductance	$L_{q\ u-v}$	[mH]	0.310	0.104	1.240	0.773	15.889	15.889
Electrical time constant	T_e	[ms]	0.56	0.57	0.55	0.55	0.57	0.57
Thermal resistance	R_{th}	[°C/W]			4.07			
Mechanical time constant (a)	T_m	[ms]	1.01	0.92	1.01	1.00	0.97	0.97
Rotor inertia without holding brake	J	[kg·cm ²]			0.0305			
Rotor inertia with holding brake	J	[kg·cm ²]			0.0326			
Mass without holding brake	m	[kg]			0.40			
Mass with holding brake	m	[kg]			0.56			
Max. axial shaft load 3000 / 6000 rpm	SL_a	[N]			45 / 35			
Max. radial shaft load 3000 / 6000 rpm	SL_r	[N]			120 / 95			

Rated output with 185 x 185 x 8 mm aluminium heat sink flange coupling. Derating must be considered if the oil seal is applied - IP 54 standard shaft bushing.
(*) without brake.
(a) without brake and without feedback.

TORQUE/SPEED CHARTS

401A 77

Operative curves at 24 Vdc — Cn — Cmax

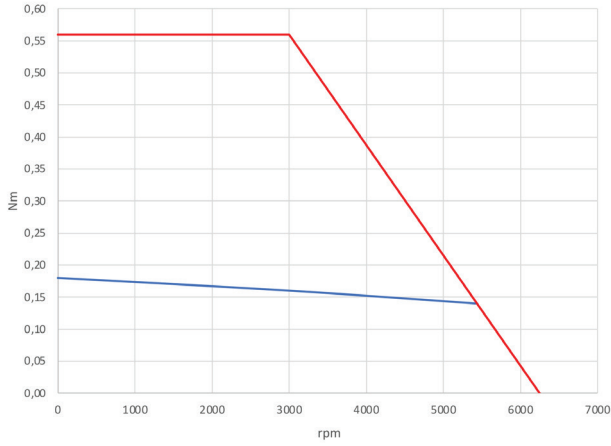

401A 41

Operative curves at 24 Vdc — Cn — Cmax

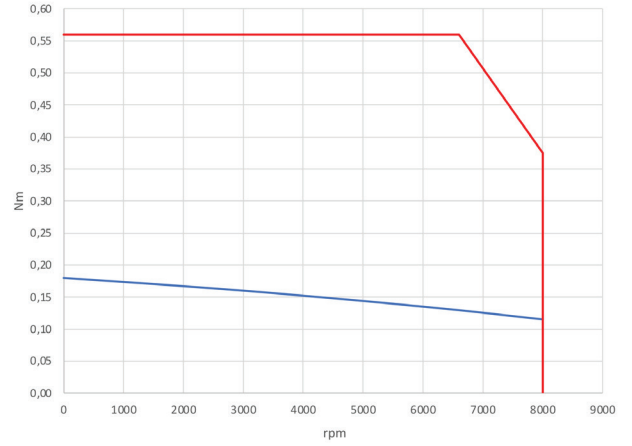

401A 78

Operative curves at 48 Vdc — Cn — Cmax

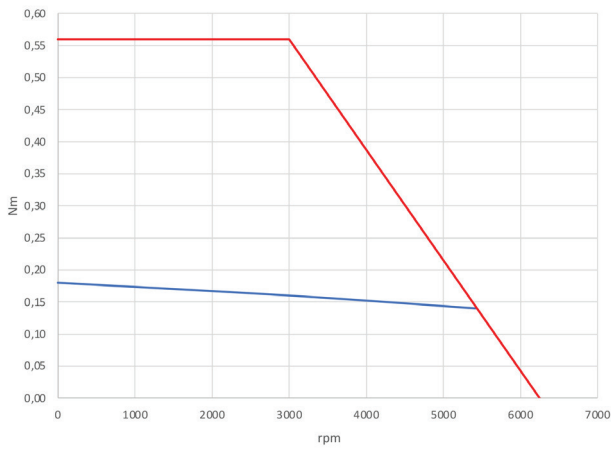

401A 33

Operative curves at 48 Vdc — Cn — Cmax

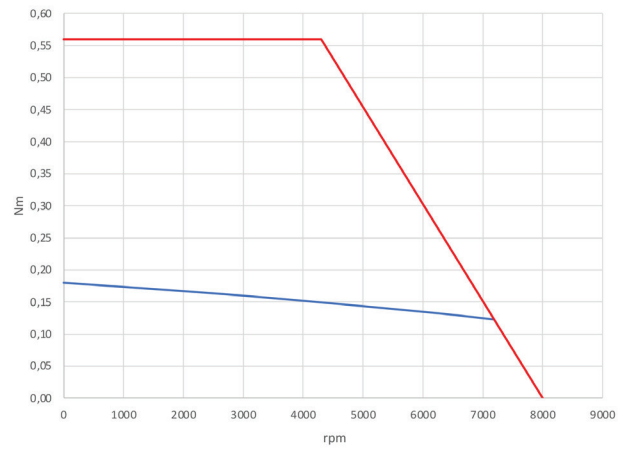

401A 09

Operative curves at 230 Vac — Cn — Cmax

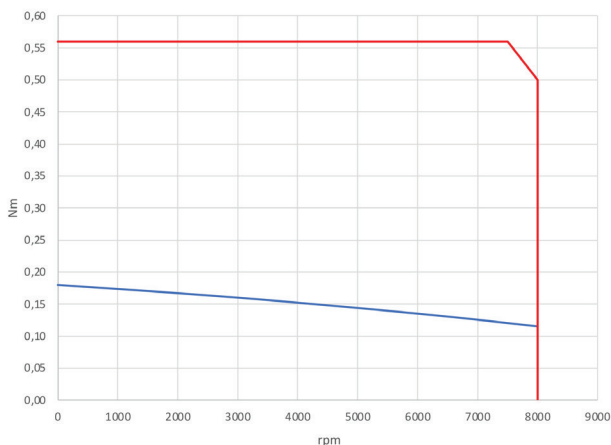

Operative temperature -20 ÷ +40 °C

Any specifications are subjected to change without notice.
All rights reserved Motor Power Company®

RATINGS and SPECIFICATION

			24 Vdc		48 Vdc		230 Vac	
TYPE OF WINDING			77	41	78	33	13	13
ELECTRICAL DATA								
Continuous stall torque (*)	M_o	[Nm]	0.33					
Peak torque	M_{Max}	[Nm]	1.12					
Nominal torque	M_n	[Nm]	0.32	0.28	0.32	0.28	0.32	0.28
Nominal power	P_n	[W]	100	175	100	175	100	175
Continuous stall current	I_o	[Arms]	7.98	13.30	3.99	4.99	0.73	0.73
Maximum current	I_{Max}	[Arms]	30.10	50.16	15.05	18.81	2.74	2.74
Nominal current	I_n	[Arms]	8.15	11.88	4.07	4.45	0.74	0.65
Nominal working speed	n_N	[rpm]	3000	6000	3000	6000	3000	6000
Maximum working speed	n_{Max}	[rpm]	6250	8000	6250	8000	7800	7800
Torque constant	K_t	[Nm/Arms]	0.041	0.025	0.083	0.066	0.455	0.455
Voltage constant	$K_{e\ u-v}$	[Vrms/krpm]	2.5	1.5	5.0	4.0	27.5	27.5
Winding resistance @ 20 °C	R_{u-v}	[Ohm]	0.253	0.087	1.019	0.632	30.848	30.848
Winding inductance	$L_{q\ u-v}$	[mH]	0.149	0.046	0.596	0.361	17.679	17.679
Electrical time constant	T_e	[ms]	0.59	0.53	0.59	0.57	0.57	0.57
Thermal resistance	R_{th}	[°C/W]	2.44					
Mechanical time constant (a)	T_m	[ms]	0.83	0.79	0.83	0.81	0.83	0.83
Rotor inertia without holding brake	J	[kg·cm ²]	0.0561					
Rotor inertia with holding brake	J	[kg·cm ²]	0.0580					
Mass without holding brake	m	[kg]	0.49					
Mass with holding brake	m	[kg]	0.68					
Max. axial shaft load 3000 / 6000 rpm	SL_a	[N]	45 / 35					
Max. radial shaft load 3000 / 6000 rpm	SL_r	[N]	120 / 95					

Rated output with 185 x 185 x 8 mm aluminium heat sink flange coupling. Derating must be considered if the oil seal is applied - IP 54 standard shaft bushing.

(*) without brake.

(a) without brake and without feedback.

TORQUE/SPEED CHARTS

401B 77

Operative curves at 24 Vdc — Cn — Cmax

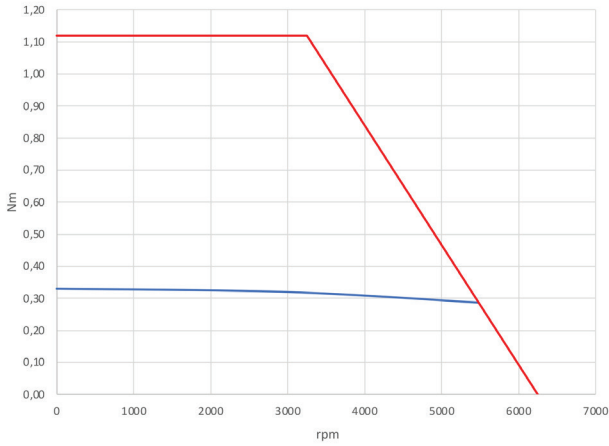

401B 41

Operative curves at 24 Vdc — Cn — Cmax

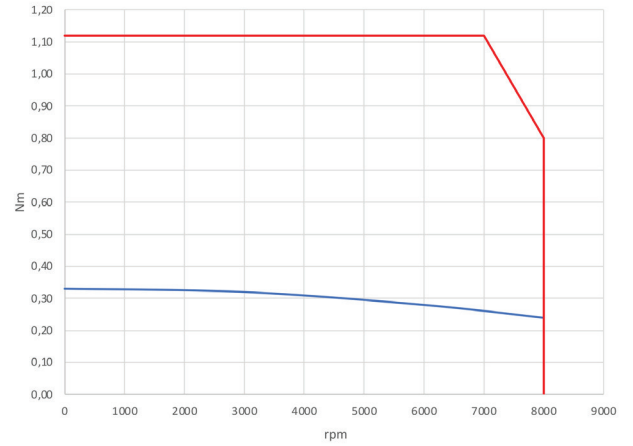

401B 78

Operative curves at 48 Vdc — Cn — Cmax

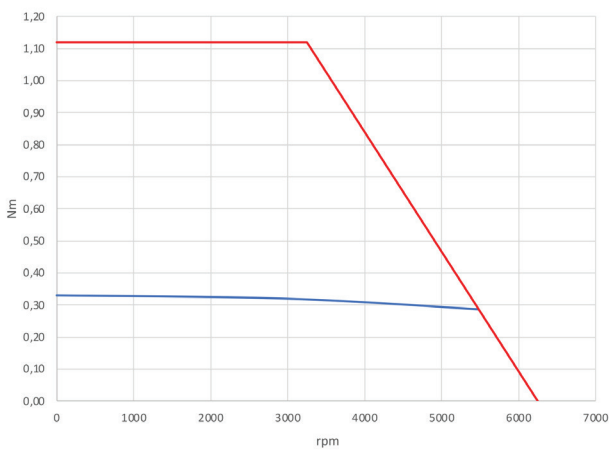

401B 33

Operative curves at 48 Vdc — Cn — Cmax

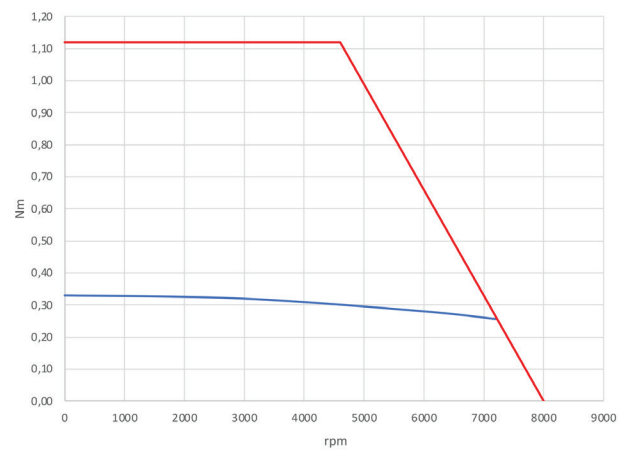

401B 13

Operative curves at 230 Vac — Cn — Cmax

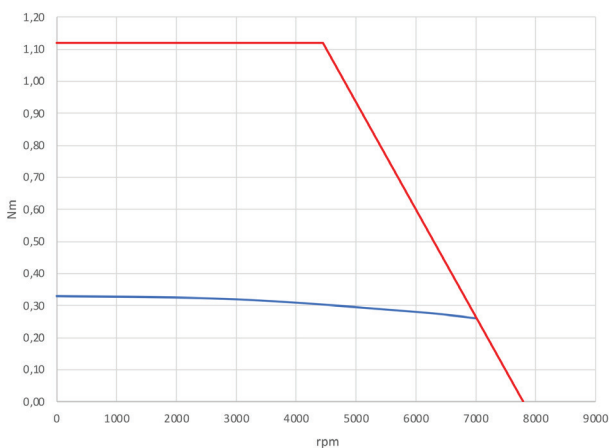

Operative temperature -20 ÷ +40 °C

Any specifications are subjected to change without notice.
All rights reserved Motor Power Company®

40 EXTERNAL DIMENSIONS

DO connection

Model	Feedback type	L [mm]	L with brake [mm]	Z [mm]	Z with brake [mm]
1A	N1-M1-M2	66.0	89.0	40.0	40.0
1B	N1-M1-M2	82.0	105.0	56.0	56.0

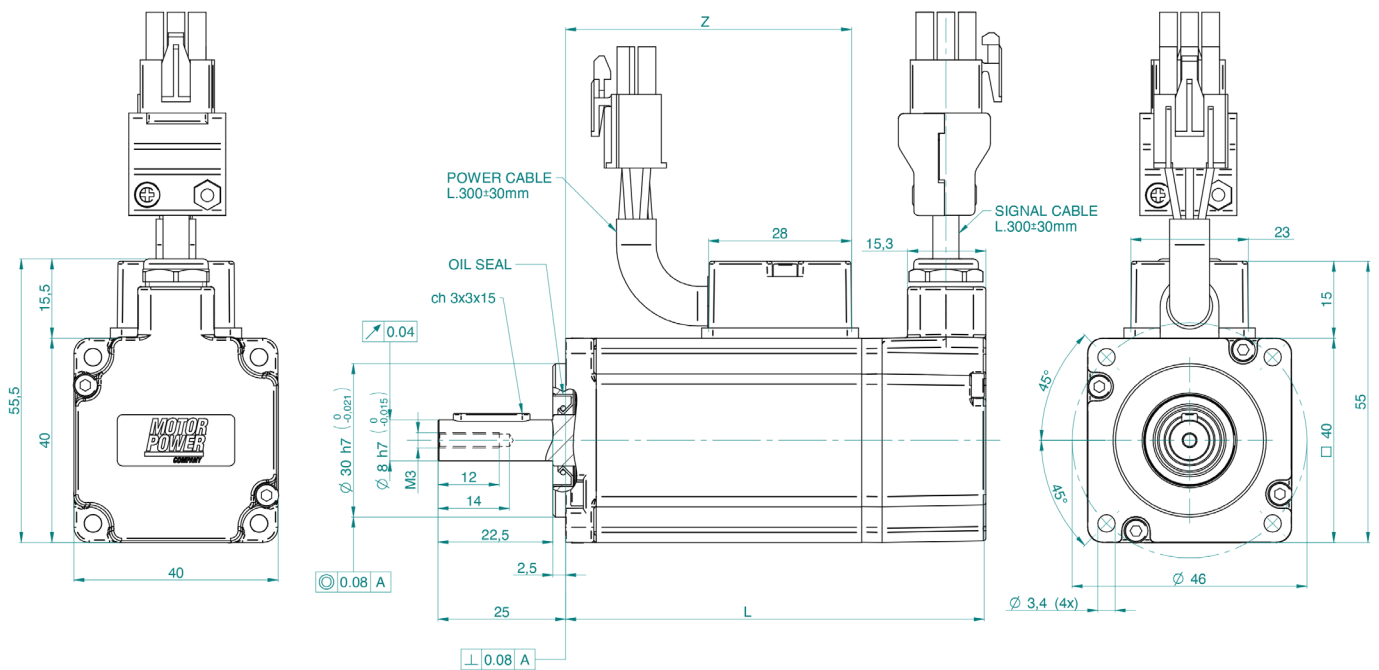

WWW.P

TETRA
COMPACT 4

60

			230 Vac		400 Vac	
TYPE OF WINDING			20	21	16	15
ELECTRICAL DATA						
Continuous stall torque (*)	M_o	[Nm]	0.67			
Peak torque	M_{Max}	[Nm]	2.24			
Nominal torque	M_n	[Nm]	0.64	0.56	0.64	0.56
Nominal power	P_n	[W]	200	350	200	350
Continuous stall current	I_o	[Arms]	0.92	1.27	0.56	0.74
Maximum current	I_{Max}	[Arms]	3.42	4.73	2.08	2.74
Nominal current	I_n	[Arms]	0.91	1.10	0.55	0.63
Nominal working speed	n_N	[rpm]	3000	6000	3000	6000
Maximum working speed	n_{Max}	[rpm]	4800	6800	5100	6800
Torque constant	K_t	[Nm/Arms]	0.728	0.526	1.2	0.91
Voltage constant	$K_{e\ u-v}$	[Vrms/krpm]	44.0	31.8	72.5	55
Winding resistance @ 20 °C	R_{u-v}	[Ohm]	20.367	10.260	52.39	31.805
Winding inductance	$L_{q\ u-v}$	[mH]	19.461	10.119	52.74	30.160
Electrical time constant	T_e	[ms]	0.96	0.99	1.01	0.95
Thermal resistance	R_{th}	[°C/W]	2.59			
Mechanical time constant (a)	T_m	[ms]	0.86	0.83	0.81	0.86
Rotor inertia without holding brake	J	[kg·cm ²]	0.223			
Rotor inertia with holding brake	J	[kg·cm ²]	0.236			
Mass without holding brake	m	[kg]	0.92			
Mass with holding brake	m	[kg]	1.44			
Max. axial shaft load 3000 / 6000 rpm	SL_a	[N]	42 / 32			
Max. radial shaft load 3000 / 6000 rpm	SL_r	[N]	260 / 200			

Rated output with 250 x 250 x 12 mm aluminium heat sink flange coupling. Derating must be considered if the oil seal is applied - IP 54 standard shaft bushing.

(*) without brake.

(a) without brake and without feedback.

TORQUE/SPEED CHARTS

602A 20

Operative curves at 230 Vac — Cn — Cmax

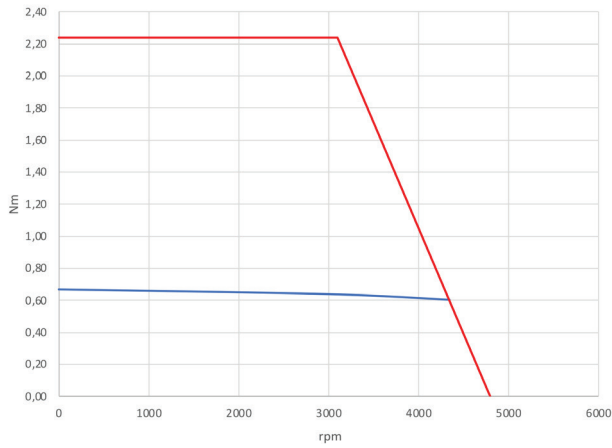

602A 21

Operative curves at 230 Vac — Cn — Cmax

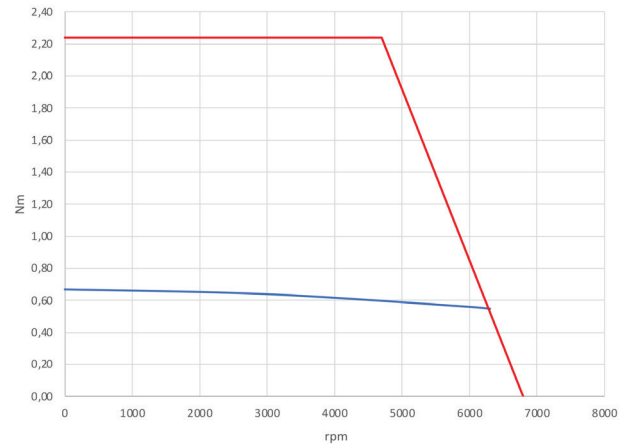

602A 16

Operative curves at 400 Vac — Cn — Cmax

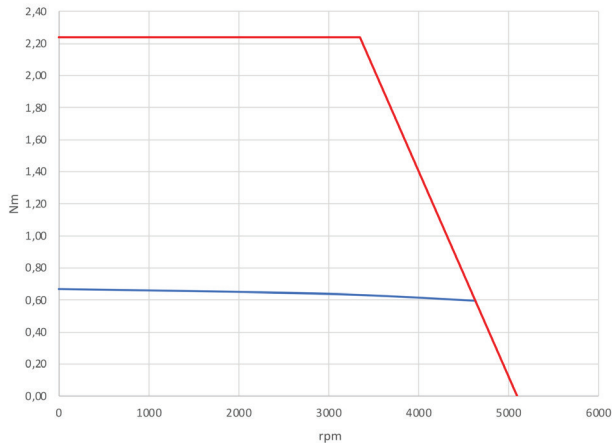

602A 15

Operative curves at 400 Vac — Cn — Cmax

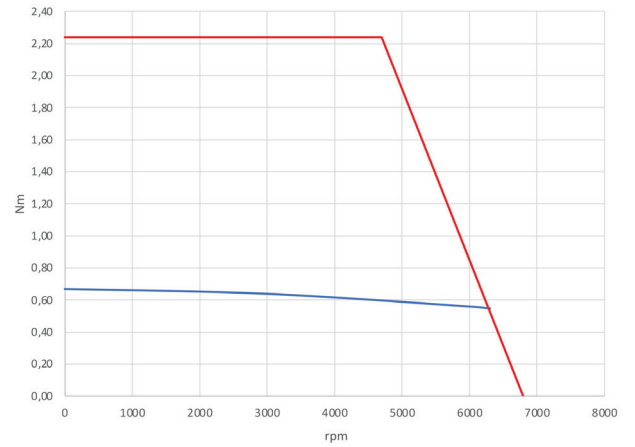

Operative temperature -20 ÷ +40 °C

Any specifications are subjected to change without notice.
All rights reserved Motor Power Company®

			230 Vac		400 Vac	
TYPE OF WINDING			20	21	16	15
ELECTRICAL DATA						
Continuous stall torque (*)	M_o	[Nm]	1.38			
Peak torque	M_{Max}	[Nm]	4.44			
Nominal torque	M_n	[Nm]	1.27	0.95	1.27	0.95
Nominal power	P_n	[W]	400	600	400	600
Continuous stall current	I_o	[Arms]	1.90	2.62	1.15	1.52
Maximum current	I_{Max}	[Arms]	6.78	9.38	4.11	5.42
Nominal current	I_n	[Arms]	1.49	1.90	1.11	1.10
Nominal working speed	n_N	[rpm]	3000	6000	3000	6000
Maximum working speed	n_{Max}	[rpm]	4900	6800	5150	6800
Torque constant	K_t	[Nm/Arms]	0.728	0.526	1.2	0.91
Voltage constant	$K_{e\ u-v}$	[Vrms/krpm]	44.0	31.8	72.5	55
Winding resistance @ 20 °C	R_{u-v}	[Ohm]	7.869	4.120	20.926	12.598
Winding inductance	$L_{q\ u-v}$	[mH]	10.836	5.690	29.579	16.833
Electrical time constant	T_e	[ms]	1.38	1.38	1.41	1.34
Thermal resistance	R_{th}	[°C/W]	1.52			
Mechanical time constant (a)	T_m	[ms]	0.57	0.57	0.56	0.59
Rotor inertia without holding brake	J	[kg·cm ²]	0.414			
Rotor inertia with holding brake	J	[kg·cm ²]	0.427			
Mass without holding brake	m	[kg]	1.33			
Mass with holding brake	m	[kg]	1.85			
Max. axial shaft load 3000 / 6000 rpm	SL_a	[N]	42 / 32			
Max. radial shaft load 3000 / 6000 rpm	SL_r	[N]	260 / 200			

Rated output with 250 x 250 x 12 mm aluminium heat sink flange coupling. Derating must be considered if the oil seal is applied - IP 54 standard shaft bushing. (*) without brake.

(a) without brake and without feedback.

TORQUE/SPEED CHARTS

602B 20

Operative curves at 230 Vac — Cn — Cmax

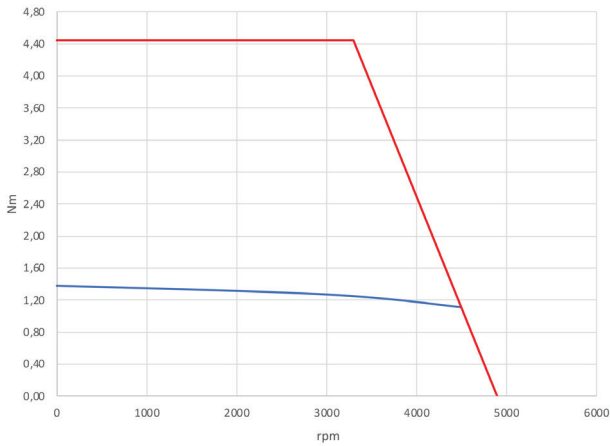

602B 21

Operative curves at 230 Vac — Cn — Cmax

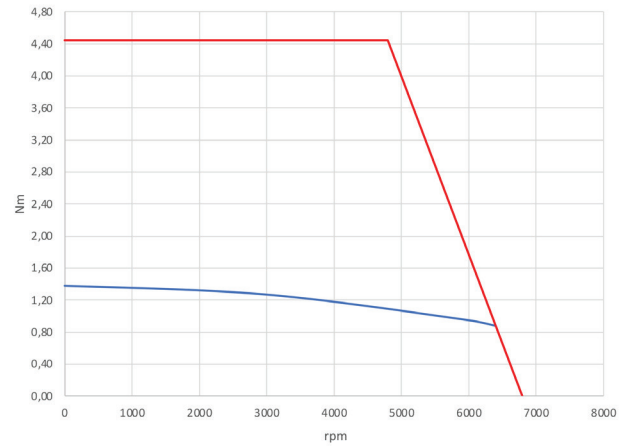

602B 16

Operative curves at 400 Vac — Cn — Cmax

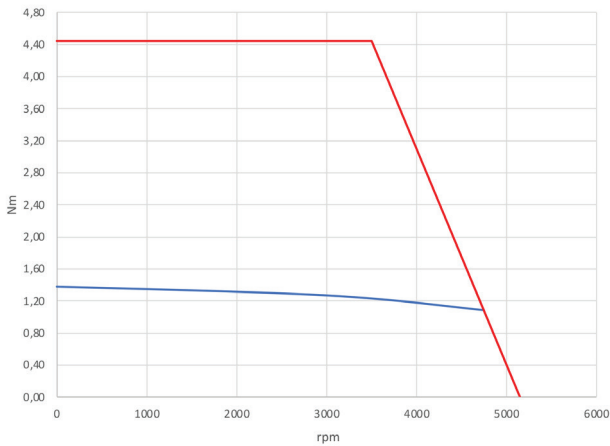

602B 15

Operative curves at 400 Vac — Cn — Cmax

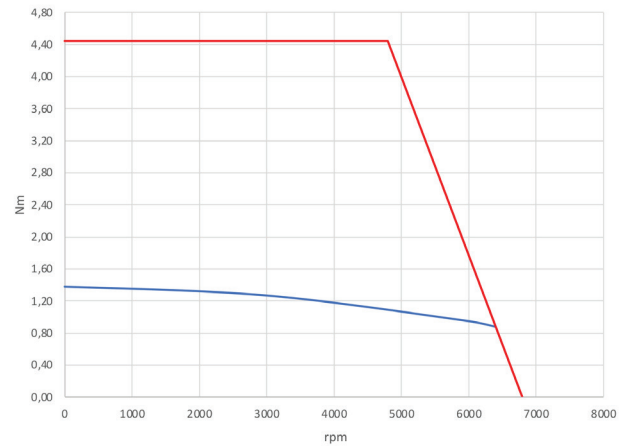

Operative temperature -20 ÷ +40 °C

Any specifications are subjected to change without notice.
All rights reserved Motor Power Company®

WORLD
P

TETRA
COMPACT 4

80

			230 Vac		400 Vac	
TYPE OF WINDING			20	21	16	15
ELECTRICAL DATA						
Continuous stall torque (*)	M_o	[Nm]	1.38			
Peak torque	M_{Max}	[Nm]	4.44			
Nominal torque	M_n	[Nm]	1.27	1.12	1.27	1.12
Nominal power	P_n	[W]	400	700	400	700
Continuous stall current	I_o	[Arms]	1.90	2.62	1.15	1.52
Maximum current	I_{Max}	[Arms]	6.78	9.38	4.11	5.42
Nominal current	I_n	[Arms]	1.84	2.24	1.11	1.3
Nominal working speed	n_N	[rpm]	3000	6000	3000	6000
Maximum working speed	n_{Max}	[rpm]	4900	6800	5200	6800
Torque constant	K_t	[Nm/Arms]	0.728	0.526	1.2	0.91
Voltage constant	$K_{e\ u-v}$	[Vrms/krpm]	44.0	31.8	72.5	55
Winding resistance @ 20 °C	R_{u-v}	[Ohm]	6.125	3.080	15.840	9.45
Winding inductance	$L_{q\ u-v}$	[mH]	11.766	6.170	32.235	18.385
Electrical time constant	T_e	[ms]	1.92	2.00	2.04	1.95
Thermal resistance	R_{th}	[°C/W]	1.97			
Mechanical time constant (a)	T_m	[ms]	0.93	0.89	0.88	0.92
Rotor inertia without holding brake	J	[kg·cm ²]	0.79			
Rotor inertia with holding brake	J	[kg·cm ²]	0.86			
Mass without holding brake	m	[kg]	1.83			
Mass with holding brake	m	[kg]	2.62			
Max. axial shaft load 3000 / 6000 rpm	SL_a	[N]	115 / 90			
Max. radial shaft load 3000 / 6000 rpm	SL_r	[N]	440 / 350			

Rated output with 250 x 250 x 12 mm aluminium heat sink flange coupling. Derating must be considered if the oil seal is applied - IP 54 standard shaft bushing.

(*) without brake.

(a) without brake and without feedback.

TORQUE/SPEED CHARTS

803A 20

Operative curves at 230 Vac — Cn — Cmax

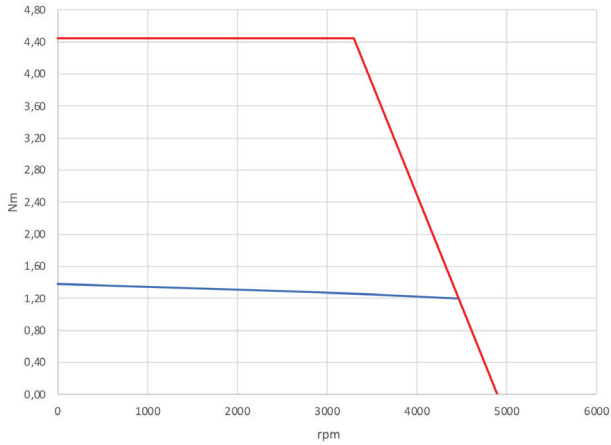

803A 21

Operative curves at 230 Vac — Cn — Cmax

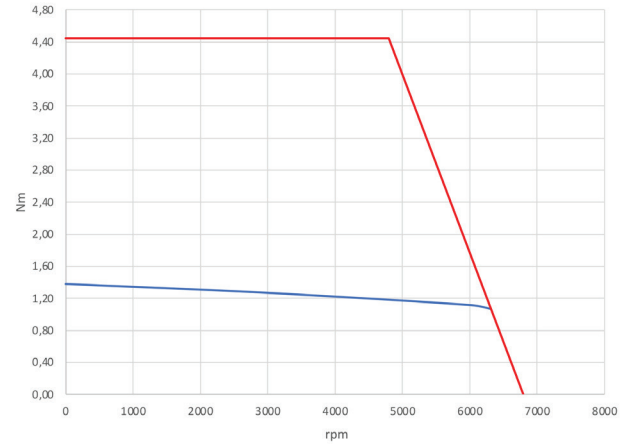

803A 16

Operative curves at 400 Vac — Cn — Cmax

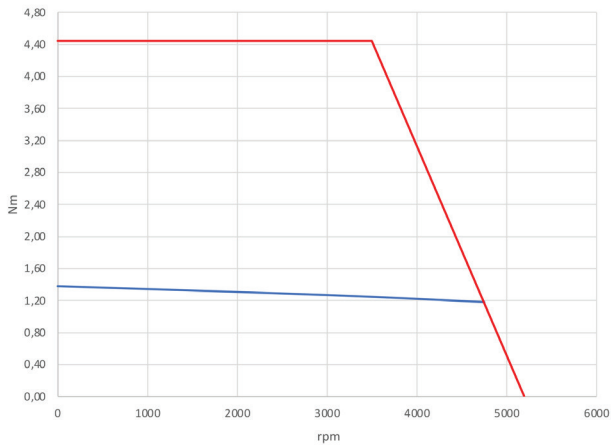

803A 15

Operative curves at 400 Vac — Cn — Cmax

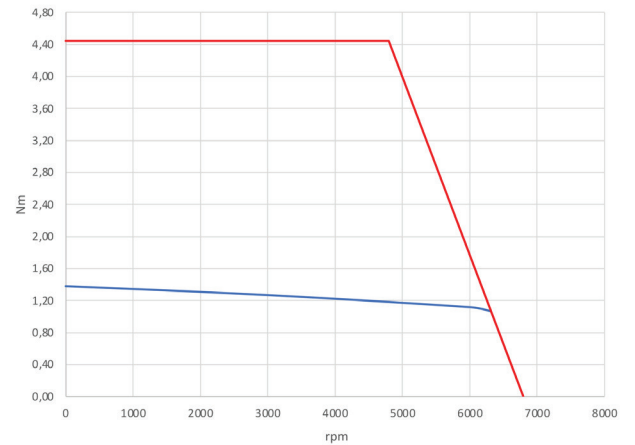

Operative temperature -20 ÷ +40 °C

Any specifications are subjected to change without notice.
All rights reserved Motor Power Company®

			230 Vac		400 Vac	
TYPE OF WINDING			20	21	16	15
ELECTRICAL DATA						
Continuous stall torque (*)	M_o	[Nm]	2.64			
Peak torque	M_{Max}	[Nm]	8.33			
Nominal torque	M_n	[Nm]	2.38	1.75	2.38	1.75
Nominal power	P_n	[W]	750	1100	750	1100
Continuous stall current	I_o	[Arms]	3.63	5.02	2.20	2.90
Maximum current	I_{Max}	[Arms]	12.72	17.60	7.72	10.17
Nominal current	I_n	[Arms]	3.44	3.50	2.09	2.02
Nominal working speed	n_N	[rpm]	3000	6000	3000	6000
Maximum working speed	n_{Max}	[rpm]	4900	6800	5350	6800
Torque constant	K_t	[Nm/Arms]	0.728	0.526	1.2	0.91
Voltage constant	$K_{e\ u-v}$	[Vrms/krpm]	44.0	31.8	72.5	55
Winding resistance @ 20 °C	R_{u-v}	[Ohm]	2.351	1.216	6.319	3.794
Winding inductance	$L_{q\ u-v}$	[mH]	4.785	2.544	13.291	7.728
Electrical time constant	T_e	[ms]	2.04	2.09	2.10	2.04
Thermal resistance	R_{th}	[°C/W]	1.35			
Mechanical time constant (a)	T_m	[ms]	0.61	0.61	0.61	0.63
Rotor inertia without holding brake	J	[kg-cm ²]	1.42			
Rotor inertia with holding brake	J	[kg-cm ²]	1.50			
Mass without holding brake	m	[kg]	2.76			
Mass with holding brake	m	[kg]	3.37			
Max. axial shaft load 3000 / 6000 rpm	SL_a	[N]	115 / 90			
Max. radial shaft load 3000 / 6000 rpm	SL_r	[N]	440 / 350			

Rated output with 250 x 250 x 12 mm aluminium heat sink flange coupling. Derating must be considered if the oil seal is applied - IP 54 standard shaft bushing.

(*) without brake.

(a) without brake and without feedback.

TORQUE/SPEED CHARTS

803B 20

Operative curves at 230 Vac — Cn — Cmax

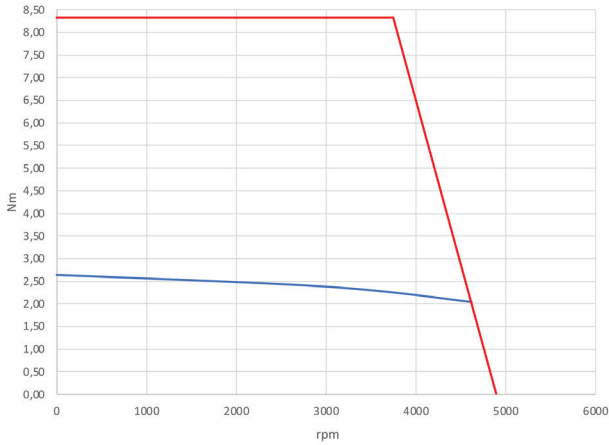

803B 21

Operative curves at 230 Vac — Cn — Cmax

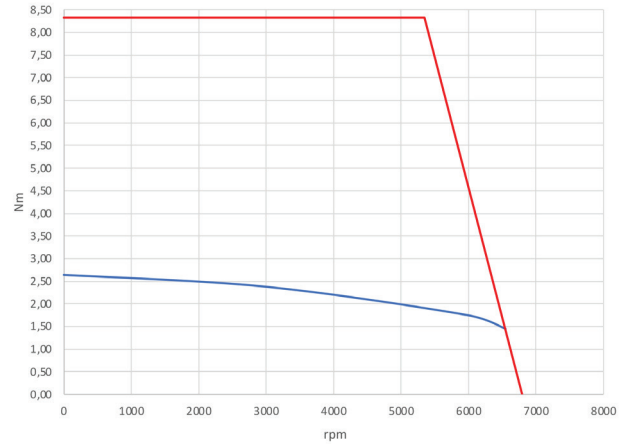

803B 16

Operative curves at 400 Vac — Cn — Cmax

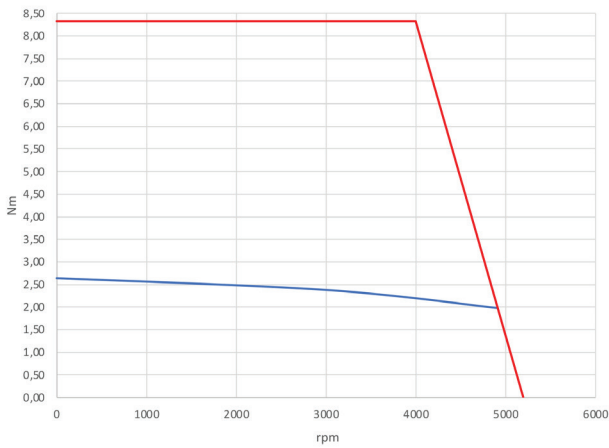

803B 15

Operative curves at 400 Vac — Cn — Cmax

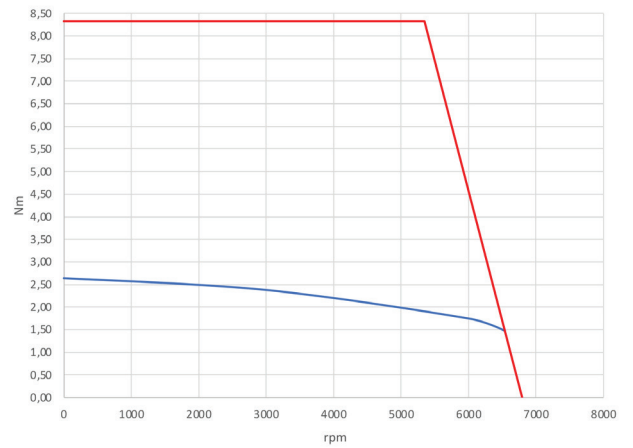

Operative temperature -20 ÷ +40 °C

Any specifications are subjected to change without notice.
All rights reserved Motor Power Company®

			230 Vac		400 Vac	
TYPE OF WINDING			20	21	16	15
ELECTRICAL DATA						
Continuous stall torque (*)	M_o	[Nm]	3.54			
Peak torque	M_{Max}	[Nm]	11.1			
Nominal torque	M_n	[Nm]	3.18	2.10	3.18	2.10
Nominal power	P_n	[W]	1000	1300	1000	1300
Continuous stall current	I_o	[Arms]	4.86	6.73	2.95	3.89
Maximum current	I_{Max}	[Arms]	16.95	23.45	10.29	13.56
Nominal current	I_n	[Arms]	4.50	4.12	2.73	2.43
Nominal working speed	n_N	[rpm]	3000	6000	3000	6000
Maximum working speed	n_{Max}	[rpm]	4900	6800	5200	6800
Torque constant	K_t	[Nm/Arms]	0.728	0.526	1.2	0.91
Voltage constant	$K_{e\ u-v}$	[Vrms/krpm]	44.0	31.8	72.5	55
Winding resistance @ 20 °C	R_{u-v}	[Ohm]	1.369	0.726	3.648	2.189
Winding inductance	$L_{q\ u-v}$	[mH]	3.729	2.025	10.250	5.950
Electrical time constant	T_e	[ms]	2.72	2.79	2.81	2.72
Thermal resistance	R_{th}	[°C/W]	1.25			
Mechanical time constant (a)	T_m	[ms]	0.52	0.53	0.51	0.53
Rotor inertia without holding brake	J	[kg-cm ²]	2.03			
Rotor inertia with holding brake	J	[kg-cm ²]	2.11			
Mass without holding brake	m	[kg]	3.25			
Mass with holding brake	m	[kg]	3.87			
Max. axial shaft load 3000 / 6000 rpm	SL_a	[N]	115 / 90			
Max. radial shaft load 3000 / 6000 rpm	SL_r	[N]	440 / 350			

Rated output with 250 x 250 x 12 mm aluminium heat sink flange coupling. Derating must be considered if the oil seal is applied - IP 54 standard shaft bushing.

(*) without brake.

(a) without brake and without feedback.

TORQUE/SPEED CHARTS

803C 20

Operative curves at 230 Vac — Cn — Cmax

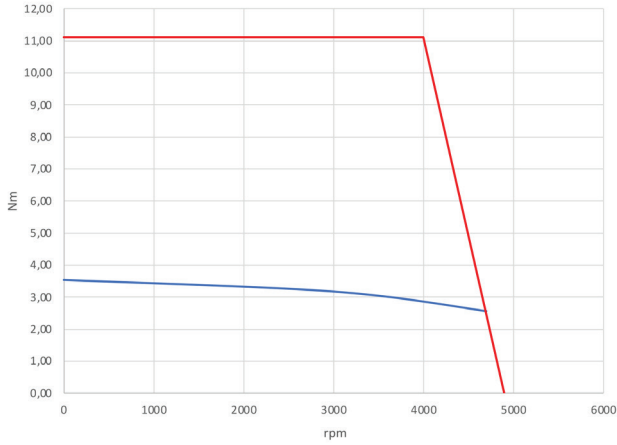

803C 21

Operative curves at 230 Vac — Cn — Cmax

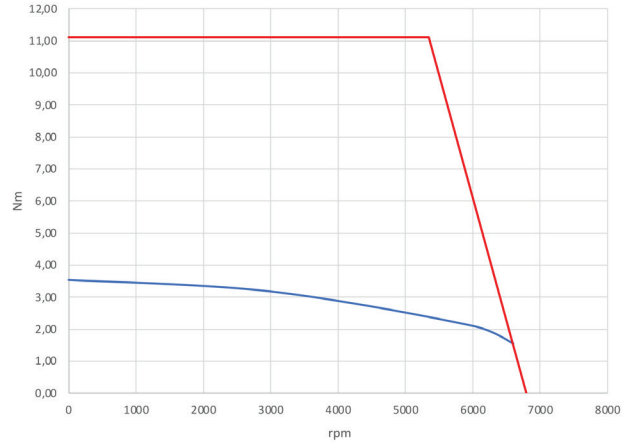

803C 16

Operative curves at 400 Vac — Cn — Cmax

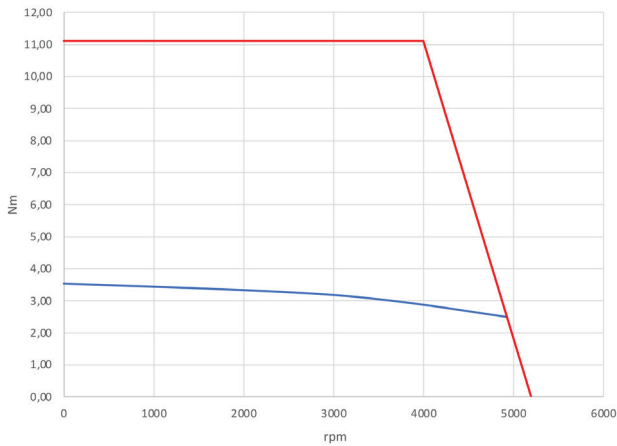

803C 15

Operative curves at 400 Vac — Cn — Cmax

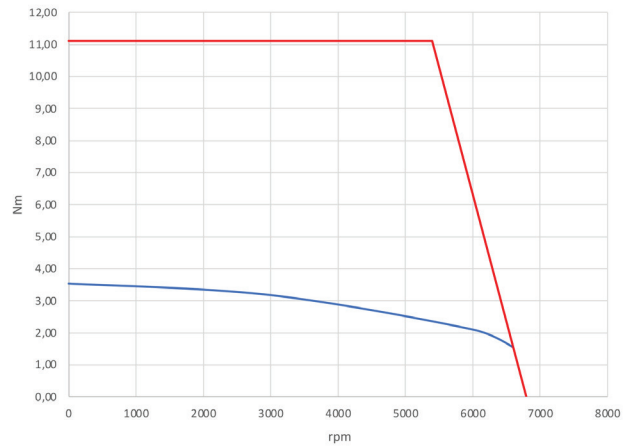

Operative temperature -20 ÷ +40 °C

Any specifications are subjected to change without notice.
All rights reserved Motor Power Company®

80 EXTERNAL DIMENSIONS

D0 connection

Model	Feedback type	L [mm]	L with brake [mm]	Z [mm]	Z with brake [mm]
3A	N1-M1-M2	93.0	125.0	62.5	62.5
3B	N1-M1-M2	115.0	147.0	84.5	84.5
3C	N1-M1-M2	127.0	159.0	96.0	96.0

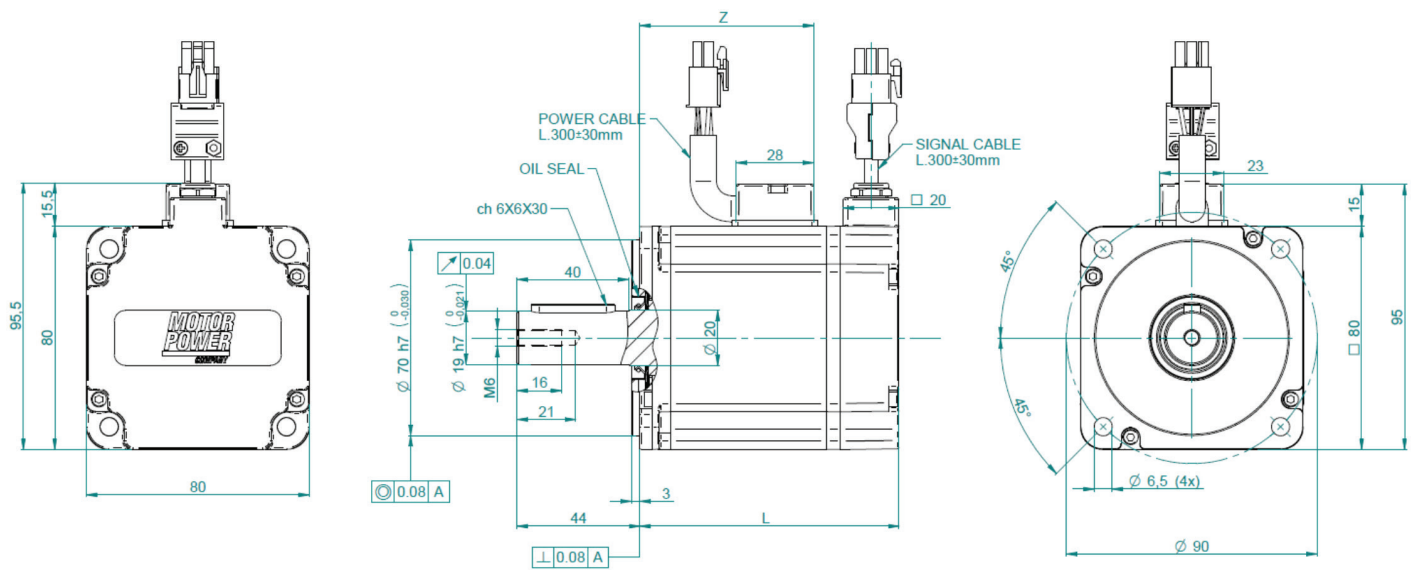

D0 connection

Model	Feedback type	L [mm]	L with brake [mm]	Z [mm]	Z with brake [mm]
3A	A1	120	152	62.5	62.5
3B	A1	142	174	84.5	84.5
3C	A1	154	186	96.0	96.0

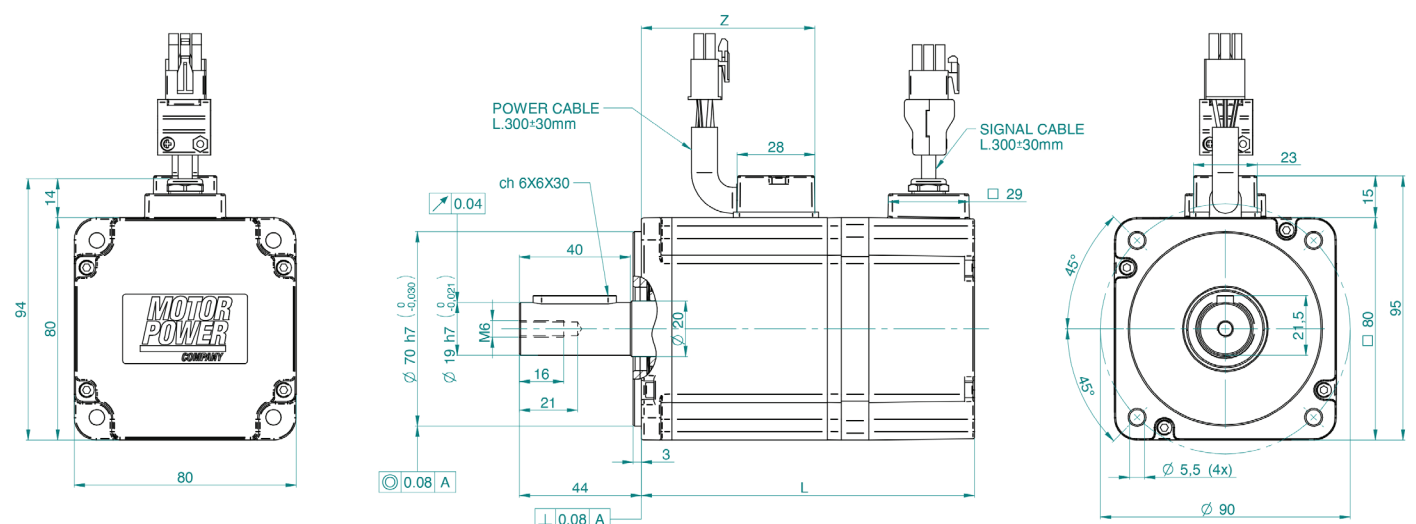

WWW.P

TETRA
COMPACT 4

100

100 4A RATINGS and SPECIFICATION

			230 Vac		400 Vac	
			D1	15	D6	17
ELECTRICAL DATA						
Continuous stall torque (*)	M_o	[Nm]	4.0			
Peak torque	M_{Max}	[Nm]	16.5			
Nominal torque	M_n	[Nm]	3.18			
Nominal power	P_n	[W]	1000			
Continuous stall current	I_o	[Arms]	7.33	4.40	6.36	2.50
Maximum current	I_{Max}	[Arms]	35.56	21.34	30.89	12.14
Nominal current	I_n	[Arms]	6.26	3.76	5.44	2.14
Nominal working speed	n_N	[rpm]	3000			
Maximum working speed	n_{Max}	[rpm]	6000	3900	6000	3900
Torque constant	K_t	[Nm/Arms]	0.55	0.91	0.63	1.60
Voltage constant	$K_{e\ u-v}$	[Vrms/krpm]	33.0	55.0	38.0	96.7
Winding resistance @ 20 °C	R_{u-v}	[Ohm]	0.64	1.82	0.80	5.12
Winding inductance	$L_{q\ u-v}$	[mH]	4.85	13.50	6.30	41.30
Electrical time constant	T_e	[ms]	7.6	7.4	7.8	8.1
Thermal resistance	R_{th}	[°C/W]	1.23			
Mechanical time constant (a)	T_m	[ms]	0.54	0.56	0.51	0.51
Rotor inertia without holding brake	J	[kg·cm ²]	2.53			
Rotor inertia with holding brake	J	[kg·cm ²]	2.65			
Mass without holding brake	m	[kg]	5.55			
Mass with holding brake	m	[kg]	6.60			
Max. axial shaft load 3000 / 5000 rpm	SL_a	[N]	245 / 220			
Max. radial shaft load 3000 / 5000 rpm	SL_r	[N]	690 / 580			

Rated output with 300 x 300 x 20 mm aluminium heat sink flange. Derating must be considered if the oil seal is applied - IP 54 standard shaft bushing.

(*) without brake.

(a) without brake and without feedback.

TORQUE/SPEED CHARTS

1004A D1

Operative curves at 230 Vac — Cn — Cmax

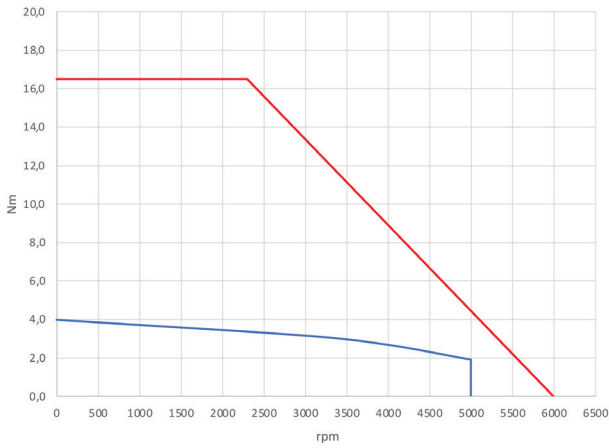

1004A 15

Operative curves at 230 Vac — Cn — Cmax

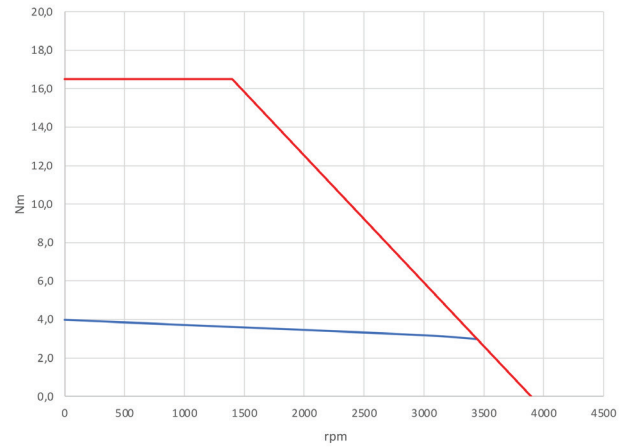

1004A D6

Operative curves at 400 Vac — Cn — Cmax

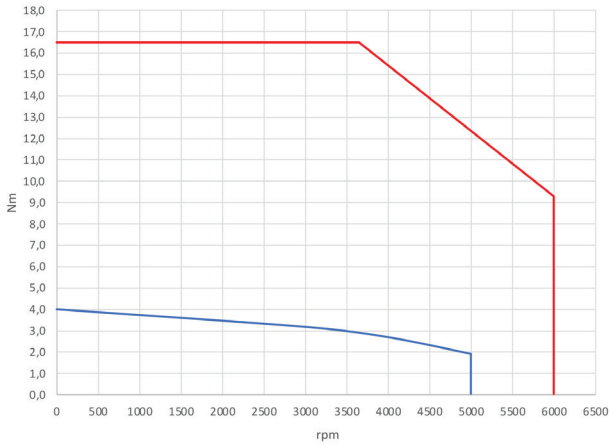

1004A 17

Operative curves at 400 Vac — Cn — Cmax

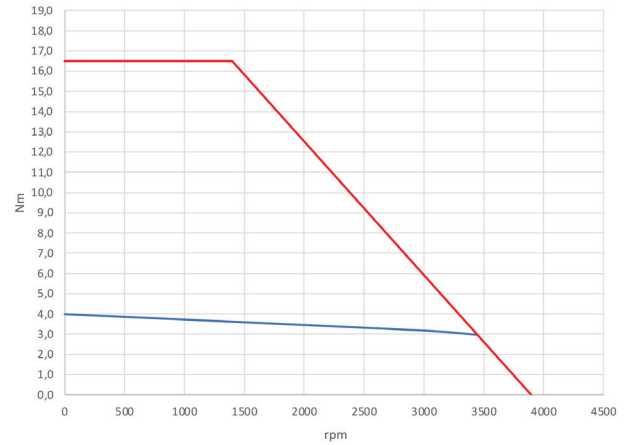

Operative temperature -20 ÷ +40 °C

Any specifications are subjected to change without notice.
All rights reserved Motor Power Company®

100 4B RATINGS and SPECIFICATION

			230 Vac		400 Vac	
TYPE OF WINDING			D5	15	H3	17
ELECTRICAL DATA						
Continuous stall torque (*)	M_o	[Nm]	8.3			
Peak torque	M_{Max}	[Nm]	33.0			
Nominal torque	M_n	[Nm]	6.37			
Nominal power	P_n	[W]	2000			
Continuous stall current	I_o	[Arms]	12.87	9.12	6.97	5.19
Maximum current	I_{Max}	[Arms]	60.19	42.68	32.60	24.27
Nominal current	I_n	[Arms]	10.62	7.53	5.75	4.28
Nominal working speed	n_N	[rpm]	3000			
Maximum working speed	n_{Max}	[rpm]	5250	3900	5000	3900
Torque constant	K_t	[Nm/Arms]	0.65	0.91	1.19	1.60
Voltage constant	$K_{e\ u-v}$	[Vrms/krpm]	39.0	55.0	72.0	96.7
Winding resistance @ 20 °C	R_{u-v}	[Ohm]	0.32	0.64	1.04	2.01
Winding inductance	$L_{q\ u-v}$	[mH]	2.45	4.87	8.35	15.14
Electrical time constant	T_e	[ms]	7.5	7.6	8.0	7.5
Thermal resistance	R_{th}	[°C/W]	0.78			
Mechanical time constant (a)	T_m	[ms]	0.36	0.35	0.34	0.36
Rotor inertia without holding brake	J	[kg·cm ²]	4.61			
Rotor inertia with holding brake	J	[kg·cm ²]	4.73			
Mass without holding brake	m	[kg]	8.09			
Mass with holding brake	m	[kg]	9.14			
Max. axial shaft load 3000 / 5000 rpm	SL_a	[N]	245 / 220			
Max. radial shaft load 3000 / 5000 rpm	SL_r	[N]	690 / 580			

Rated output with 300 x 300 x 20 mm aluminium heat sink flange. Derating must be considered if the oil seal is applied - IP 54 standard shaft bushing.

(*) without brake.

(a) without brake and without feedback.

TORQUE/SPEED CHARTS

1004B D5

Operative curves at 230 Vac

— Cn — Cmax

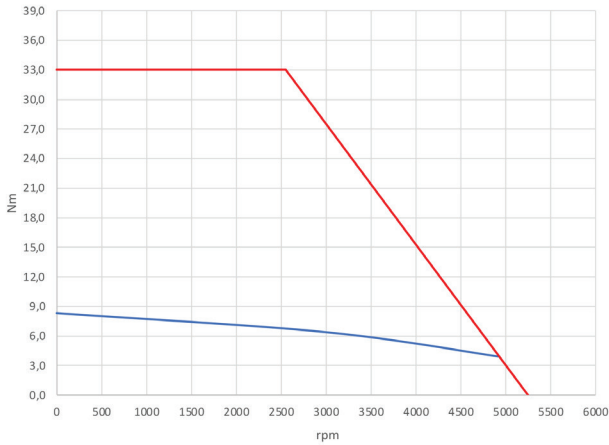

1004B 15

Operative curves at 230 Vac

— Cn — Cmax

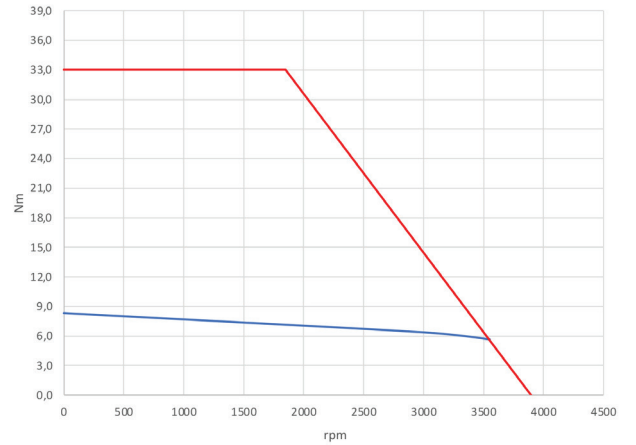

1004B H3

Operative curves at 400 Vac

— Cn — Cmax

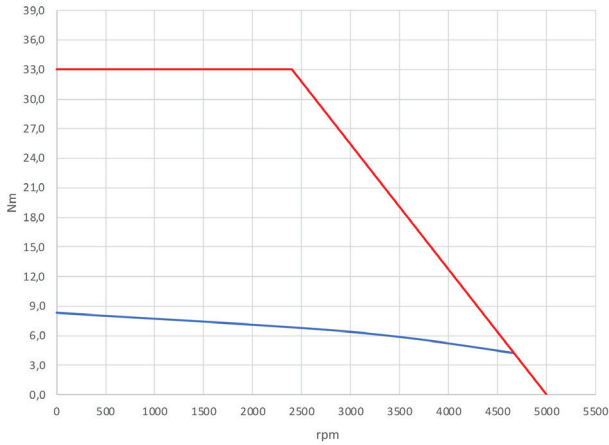

1004B 17

Operative curves at 400 Vac

— Cn — Cmax

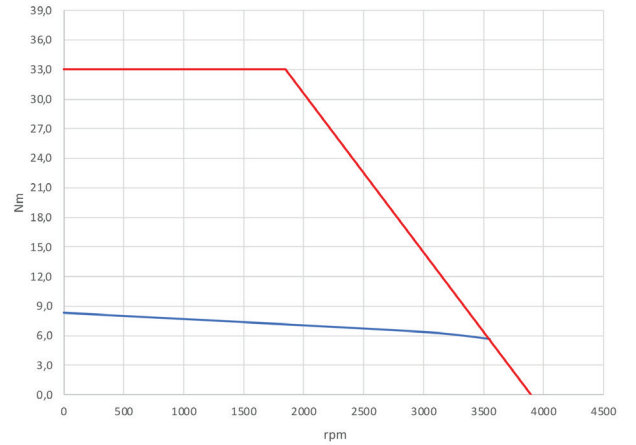

Operative temperature -20 ÷ +40 °C

Any specifications are subjected to change without notice.
All rights reserved Motor Power Company®

TC4

100

EXTERNAL DIMENSIONS

G2/H2 connection

Model	Feedback type	L [mm]	L with brake [mm]	Z [mm]	Z with brake [mm]
4A	A1-M1-M2-R1	173.0	203.0	103.5	103.5
4B	A1-M1-M2-R1	218.0	248.0	149.0	149.0

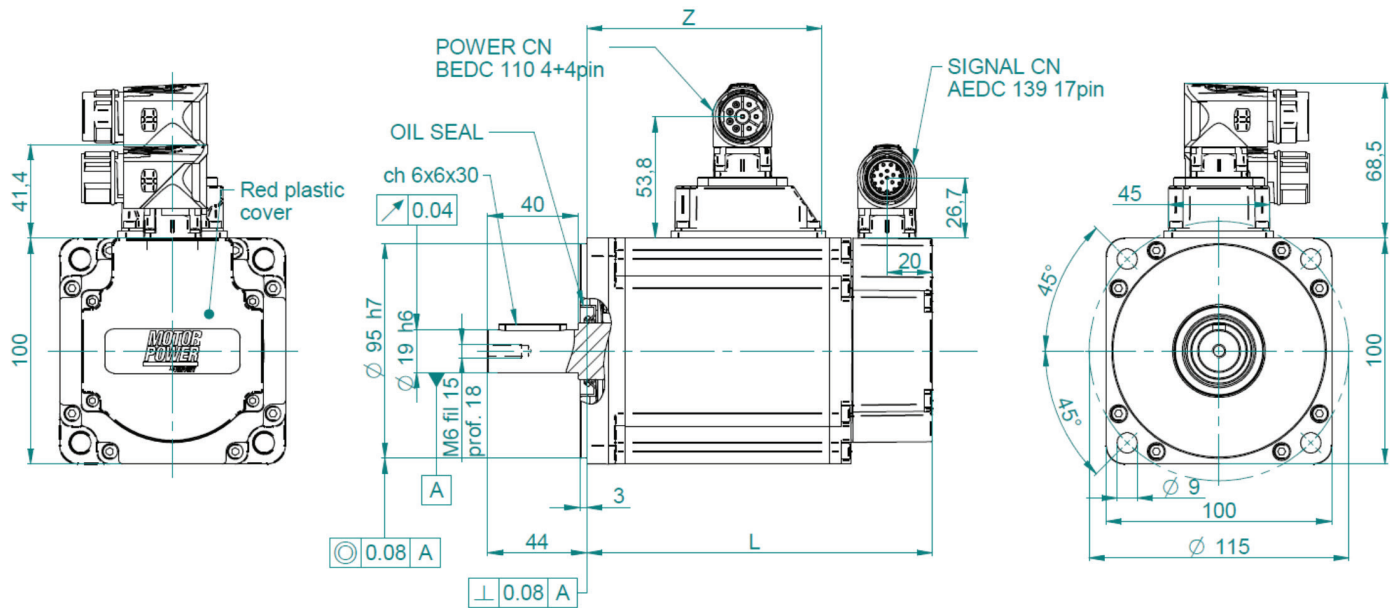

C21 connection

Model	Feedback type	L [mm]	L with brake [mm]
4A	A22-A23	159,5	189
4B	A22-A23	204,5	234

C21 connection

Model	Feedback type	L [mm]	L with brake [mm]
4A	A3-A4-A5-A6-A15-A16	175,5	205
4B	A3-A4-A5-A6-A15-A16	220,5	250

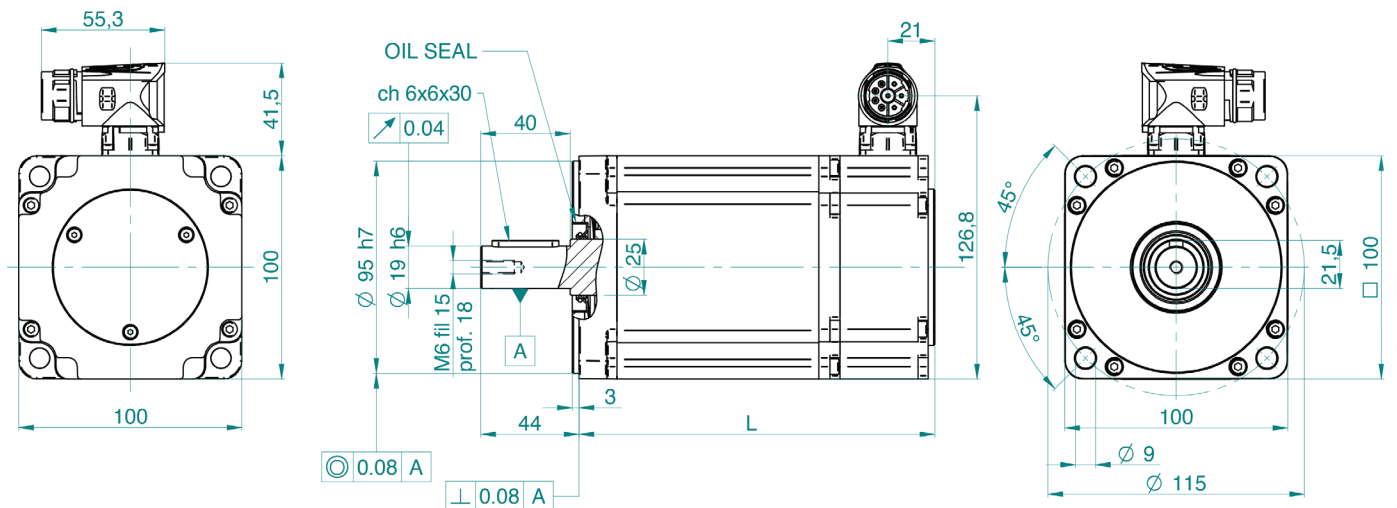

WWW
P

TETRA
COMPACT 4

130

130 5F RATINGS and SPECIFICATION

	TYPE OF WINDING	230/400 Vac	
		F1	
ELECTRICAL DATA			
Continuous stall torque (*)	M_o	[Nm]	4.77
Peak torque	M_{Max}	[Nm]	14.3
Nominal torque	M_n	[Nm]	3.18
Nominal power	P_n	[W]	1000
Continuous stall current	I_o	[Arms]	5.77
Maximum current	I_{Max}	[Arms]	19.2
Nominal current	I_n	[Arms]	4.14
Nominal working speed	n_N	[rpm]	3000
Maximum working speed	n_{Max}	[rpm]	4000
Torque constant	K_t	[Nm/Arms]	0.83
Voltage constant	$K_{e\ u-v}$	[Vrms/krpm]	50
Winding resistance @ 20 °C	R_{u-v}	[Ohm]	0.71
Winding inductance	$L_{q\ u-v}$	[mH]	7.84
Electrical time constant	T_e	[ms]	11.1
Thermal resistance	R_{th}	[°C/W]	-
Mechanical time constant (a)	T_m	[ms]	0.69
Rotor inertia without holding brake	J	[kg·cm ²]	6.70
Rotor inertia with holding brake	J	[kg·cm ²]	7.95
Mass without holding brake	m	[kg]	7.35
Mass with holding brake	m	[kg]	8.87
Max. axial shaft load 2000 rpm	SL_a	[N]	230
Max. radial shaft load 2000 rpm	SL_r	[N]	1200

Rated output with 400 x 400 x 20 mm aluminium heat sink flange. Derating must be considered if the oil seal is applied - IP 54 standard shaft bushing.
 (*) without brake. (a) without brake and without feedback.

TORQUE/SPEED CHARTS

Operative temperature -20 ÷ +40 °C

Any specifications are subjected to change without notice.
 All rights reserved Motor Power Company®

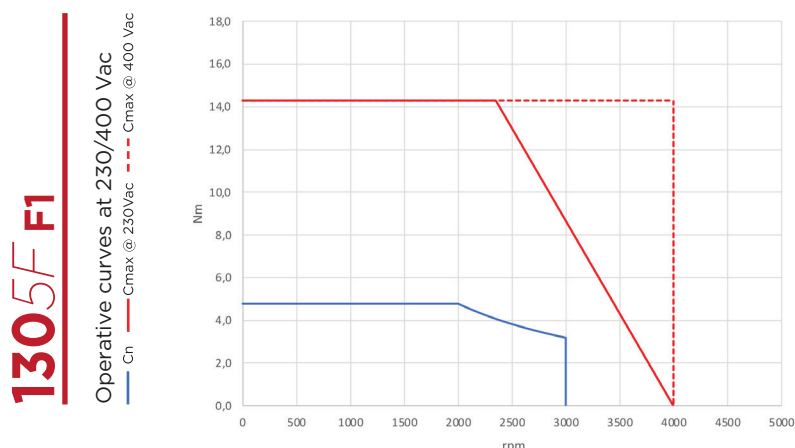

130 5G RATINGS and SPECIFICATION

	TYPE OF WINDING	230/400 Vac	
			H1
ELECTRICAL DATA			
Continuous stall torque (*)	M_o	[Nm]	7.16
Peak torque	M_{Max}	[Nm]	21.48
Nominal torque	M_n	[Nm]	4.78
Nominal power	P_n	[W]	1500
Continuous stall current	I_o	[Arms]	6.18
Maximum current	I_{Max}	[Arms]	20.6
Nominal current	I_n	[Arms]	4.44
Nominal working speed	n_N	[rpm]	3000
Maximum working speed	n_{Max}	[rpm]	4000
Torque constant	K_t	[Nm/Arms]	1.16
Voltage constant	$K_{e\ u-v}$	[Vrms/krpm]	70
Winding resistance @ 20 °C	R_{u-v}	[Ohm]	0.64
Winding inductance	$L_{q\ u-v}$	[mH]	7.2
Electrical time constant	T_e	[ms]	11.25
Thermal resistance	R_{th}	[°C/W]	-
Mechanical time constant (a)	T_m	[ms]	0.46
Rotor inertia without holding brake	J	[kg·cm ²]	9.72
Rotor inertia with holding brake	J	[kg·cm ²]	10.98
Mass without holding brake	m	[kg]	8.80
Mass with holding brake	m	[kg]	10.32
Max. axial shaft load 2000 rpm	SL_a	[N]	230
Max. radial shaft load 2000 rpm	SL_r	[N]	1200

Rated output with 400 x 400 x 20 mm aluminium heat sink flange. Derating must be considered if the oil seal is applied - IP 54 standard shaft bushing.
 (*) without brake. (a) without brake and without feedback.

TORQUE/SPEED CHARTS

Operative temperature -20 ÷ +40 °C

Any specifications are subjected to change without notice.
 All rights reserved Motor Power Company®

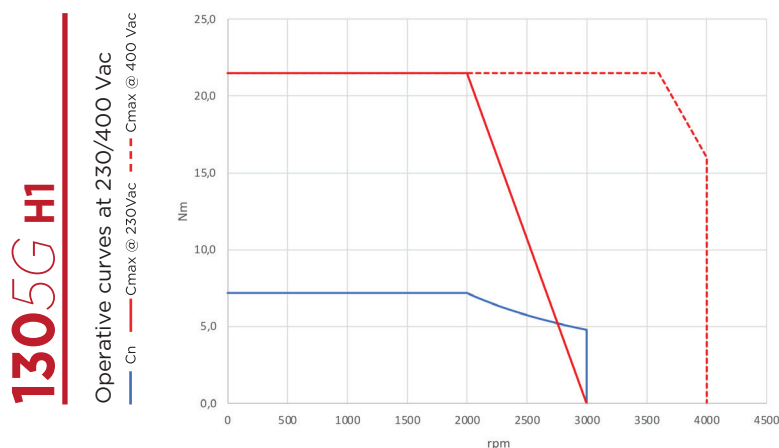

130 5H RATINGS and SPECIFICATION

	230/400 Vac
TYPE OF WINDING	22

ELECTRICAL DATA			
Continuous stall torque (*)	M_o	[Nm]	9.55
Peak torque	M_{Max}	[Nm]	28.65
Nominal torque	M_n	[Nm]	6.37
Nominal power	P_n	[W]	2000
Continuous stall current	I_o	[Arms]	9.95
Maximum current	I_{Max}	[Arms]	33.2
Nominal current	I_n	[Arms]	7.14
Nominal working speed	n_N	[rpm]	3000
Maximum working speed	n_{Max}	[rpm]	4000
Torque constant	K_t	[Nm/Arms]	0.96
Voltage constant	$K_{e\ u-v}$	[Vrms/krpm]	58
Winding resistance @ 20 °C	R_{u-v}	[Ohm]	0.46
Winding inductance	$L_{q\ u-v}$	[mH]	5.8
Electrical time constant	T_e	[ms]	12.7
Thermal resistance	R_{th}	[°C/W]	-
Mechanical time constant (a)	T_m	[ms]	0.63
Rotor inertia without holding brake	J	[kg·cm ²]	12.77
Rotor inertia with holding brake	J	[kg·cm ²]	14.04
Mass without holding brake	m	[kg]	10.54
Mass with holding brake	m	[kg]	12.68
Max. axial shaft load 2000 rpm	SL_a	[N]	230
Max. radial shaft load 2000 rpm	SL_r	[N]	1200

Rated output with 400 x 400 x 20 mm aluminium heat sink flange. Derating must be considered if the oil seal is applied - IP 54 standard shaft bushing.
 (*) without brake. (a) without brake and without feedback.

TORQUE/SPEED CHARTS

Operative temperature -20 ÷ +40 °C

Any specifications are subjected to change without notice.
 All rights reserved Motor Power Company®

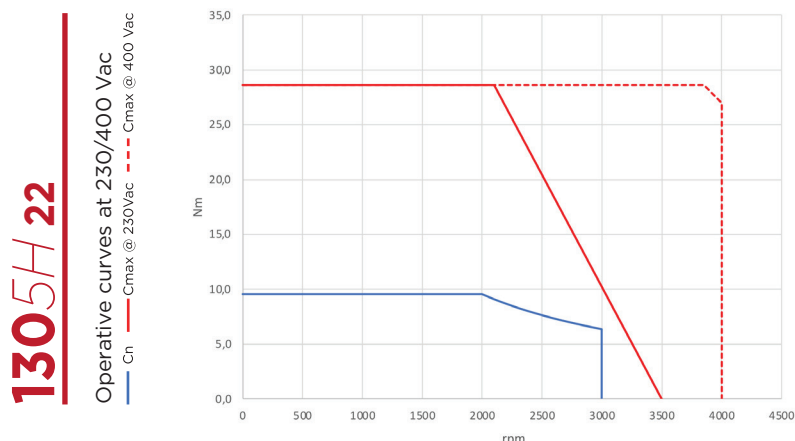

EXTERNAL DIMENSIONS 130

G2/H2 connection

Model	Feedback type	L [mm]	L with brake [mm]	Z [mm]	Z with brake [mm]
5F	A1-M1-M2-R1	162.0	191.0	94.5	94.5
5G	A1-M1-M2-R1	178.0	207.0	110.5	110.5
5H	A1-M1-M2-R1	202.0	231.0	134.5	134.5

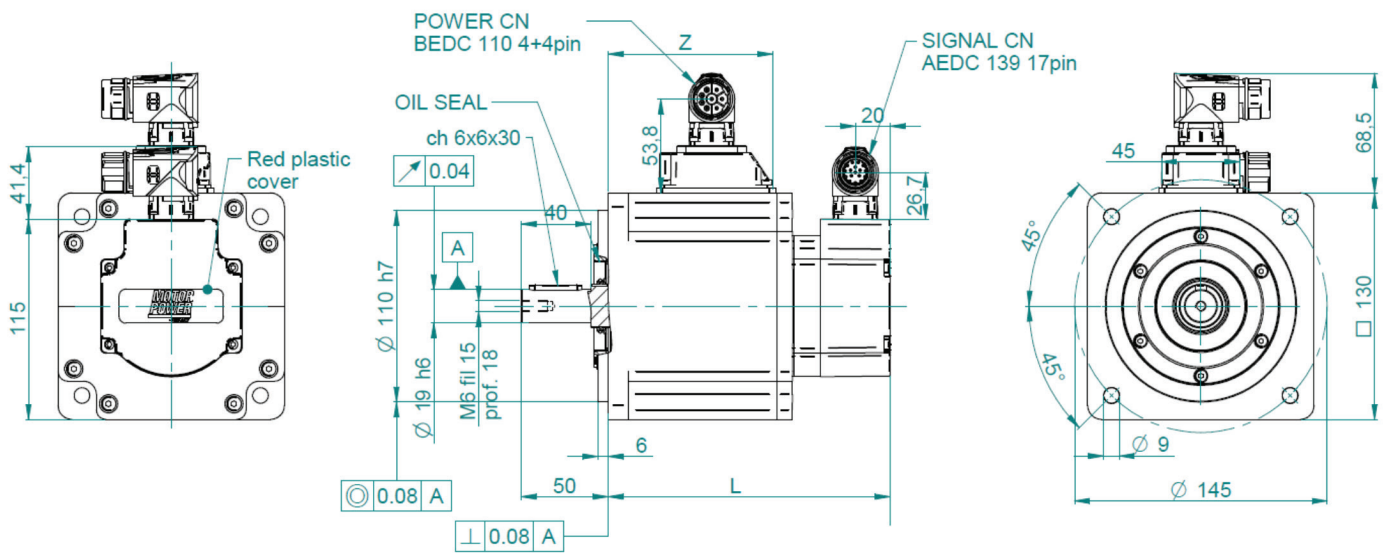

WWW.P

TETRA
COMPACT 4

150

150 6A RATINGS and SPECIFICATION

TYPE OF WINDING	230 Vac		400 Vac	
	20		70	
ELECTRICAL DATA				
Continuous stall torque (*)	M_o	[Nm]	9.55	
Peak torque	M_{Max}	[Nm]	33.425	
Nominal torque	M_n	[Nm]	7.96	
Nominal power	P_n	[W]	2500	
Continuous stall current	I_o	[Arms]	13.12	7.70
Maximum current	I_{Max}	[Arms]	51.03	29.94
Nominal current	I_n	[Arms]	11.76	6.90
Nominal working speed	n_N	[rpm]	3000	
Maximum working speed	n_{Max}	[rpm]	4000	4000
Torque constant	K_t	[Nm/Arms]	0.73	1.24
Voltage constant	$K_{e\ u-v}$	[Vrms/krpm]	44.0	75.0
Winding resistance @ 20 °C	R_{u-v}	[Ohm]	0.18	0.54
Winding inductance	$L_{q\ u-v}$	[mH]	2.54	7.35
Electrical time constant	T_e	[ms]	13.9	13.5
Thermal resistance	R_{th}	[°C/W]	1.33	
Mechanical time constant (a)	T_m	[ms]	0.52	0.54
Rotor inertia without holding brake	J	[kg·cm ²]	15.18	
Rotor inertia with holding brake	J	[kg·cm ²]	16.55	
Mass without holding brake	m	[kg]	13.68	
Mass with holding brake	m	[kg]	17.20	
Max. axial shaft load 2500 rpm	SL_a	[N]	450	
Max. radial shaft load 2500 rpm	SL_r	[N]	1850	

Rated output with 475 x 475 x 20 mm aluminium heat sink flange coupling. Derating must be considered if the oil seal is applied - IP 54 standard shaft bushing. (*) without brake. (a) without brake and without feedback.

TORQUE/SPEED CHARTS

Operative temperature -20 ÷ +40 °C

Any specifications are subjected to change without notice.
All rights reserved Motor Power Company®

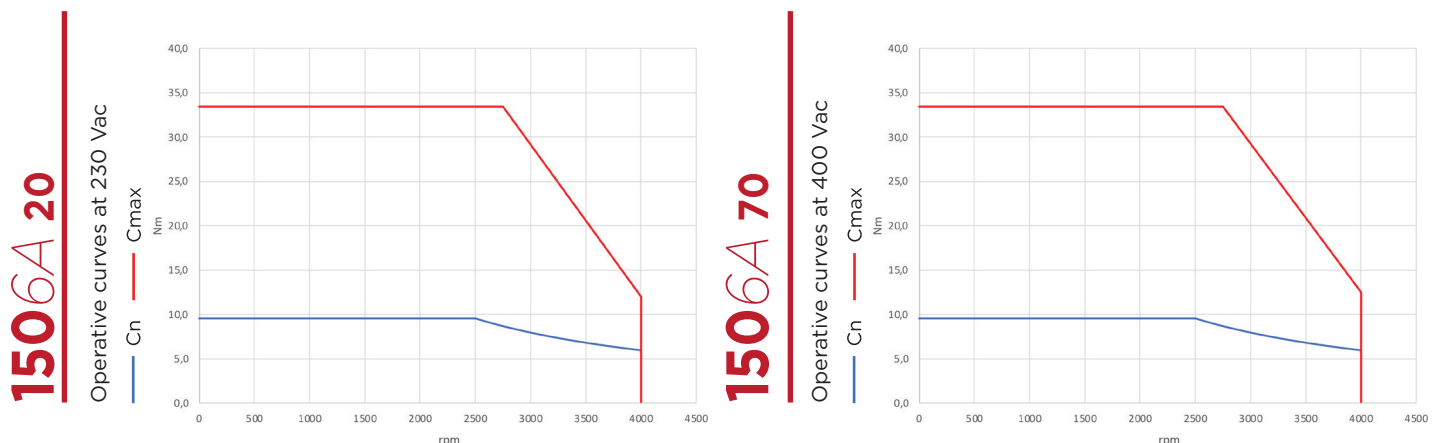

150 6B RATINGS and SPECIFICATION

TYPE OF WINDING	230 Vac		400 Vac	
	F1	15	G1	17
ELECTRICAL DATA				
Continuous stall torque (*)	M_o	[Nm]	19.10	
Peak torque	M_{Max}	[Nm]	66.85	
Nominal torque	M_n	[Nm]	12.73	
Nominal power	P_n	[W]	4000	
Continuous stall current	I_o	[Arms]	23.10	13.12
Maximum current	I_{Max}	[Arms]	89.82	51.03
Nominal current	I_n	[Arms]	16.56	9.41
Nominal working speed	n_N	[rpm]	3000	
Maximum working speed	n_{Max}	[rpm]	4000	4000
Torque constant	K_t	[Nm/Arms]	0.83	1.46
Voltage constant	$K_{e\ u-v}$	[Vrms/krpm]	50.0	88.0
Winding resistance @ 20 °C	R_{u-v}	[Ohm]	0.086	0.282
Winding inductance	$L_{q\ u-v}$	[mH]	1.60	5.090
Electrical time constant	T_e	[ms]	18.6	18.0
Thermal resistance	R_{th}	[°C/W]	0.90	
Mechanical time constant (a)	T_m	[ms]	0.35	0.37
Rotor inertia without holding brake	J	[kg·cm ²]	27.68	
Rotor inertia with holding brake	J	[kg·cm ²]	28.76	
Mass without holding brake	m	[kg]	18.00	
Mass with holding brake	m	[kg]	22.40	
Max. axial shaft load 2500 rpm	SL_a	[N]	450	
Max. radial shaft load 2500 rpm	SL_r	[N]	1850	

Rated output with 475 x 475 x 20 mm aluminium heat sink flange coupling. Derating must be considered if the oil seal is applied - IP 54 standard shaft bushing. (*) without brake. (a) without brake and without feedback.

TORQUE/SPEED CHARTS

Operative temperature -20 ÷ +40 °C

Any specifications are subjected to change without notice.
All rights reserved Motor Power Company®

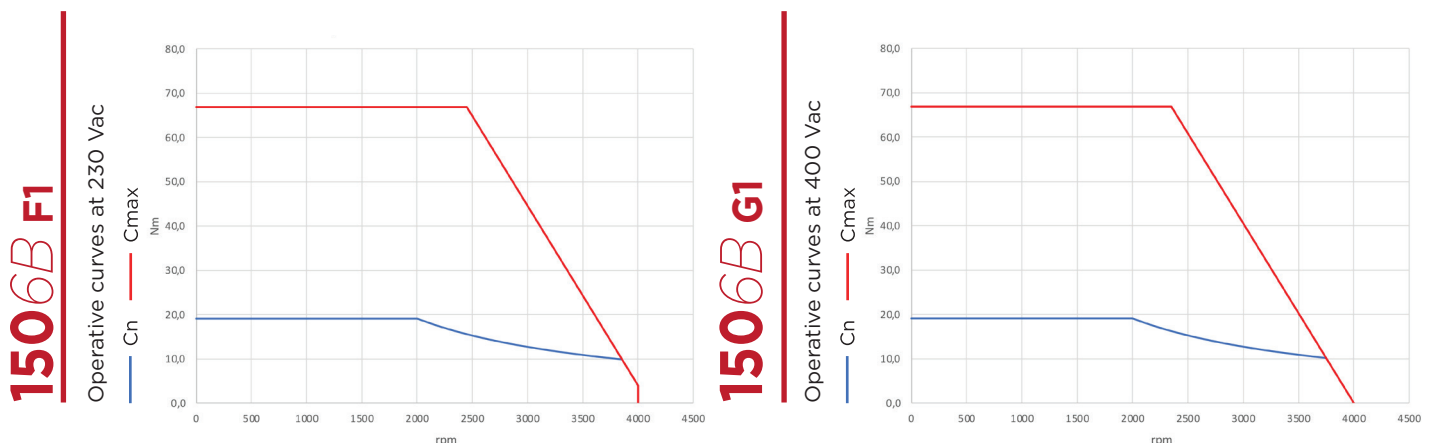

150 6C RATINGS and SPECIFICATION

ELECTRICAL DATA	TYPE OF WINDING	230 Vac		400 Vac	
		F1	15	G1	17
Continuous stall torque (*)	M_o	[Nm]		28.65	
Peak torque	M_{Max}	[Nm]		100.275	
Nominal torque	M_n	[Nm]		19.1	
Nominal power	P_n	[W]		6000	
Continuous stall current	I_o	[Arms]	34.64		19.68
Maximum current	I_{Max}	[Arms]	134.72		76.55
Nominal current	I_n	[Arms]	24.84		14.11
Nominal working speed	n_N	[rpm]		3000	
Maximum working speed	n_{Max}	[rpm]	4000		4000
Torque constant	K_t	[Nm/Arms]	0.83		1.46
Voltage constant	$K_{e\ u-v}$	[Vrms/krpm]	50.0		88.0
Winding resistance @ 20 °C	R_{u-v}	[Ohm]	0.057		0.171
Winding inductance	$L_{q\ u-v}$	[mH]	1.10		3.320
Electrical time constant	T_e	[ms]	19.4		19.4
Thermal resistance	R_{th}	[°C/W]		0.61	
Mechanical time constant (a)	T_m	[ms]	0.33		0.33
Rotor inertia without holding brake	J	[kg·cm ²]		40.17	
Rotor inertia with holding brake	J	[kg·cm ²]		41.25	
Mass without holding brake	m	[kg]		23.26	
Mass with holding brake	m	[kg]		27.67	
Max. axial shaft load 2500 rpm	SL_a	[N]		450	
Max. radial shaft load 2500 rpm	SL_r	[N]		1850	

Rated output with 475 x 475 x 20 mm aluminium heat sink flange coupling. Derating must be considered if the oil seal is applied - IP 54 standard shaft bushing. (*) without brake. (a) without brake and without feedback.

TORQUE/SPEED CHARTS

Operative temperature -20 ÷ +40 °C

Any specifications are subjected to change without notice.
All rights reserved Motor Power Company®

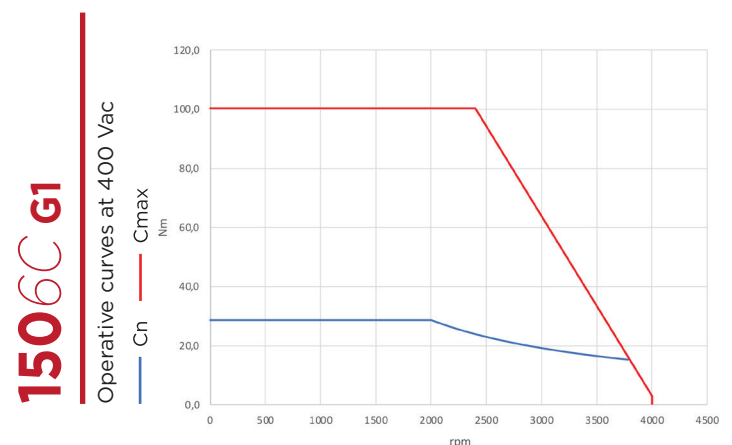
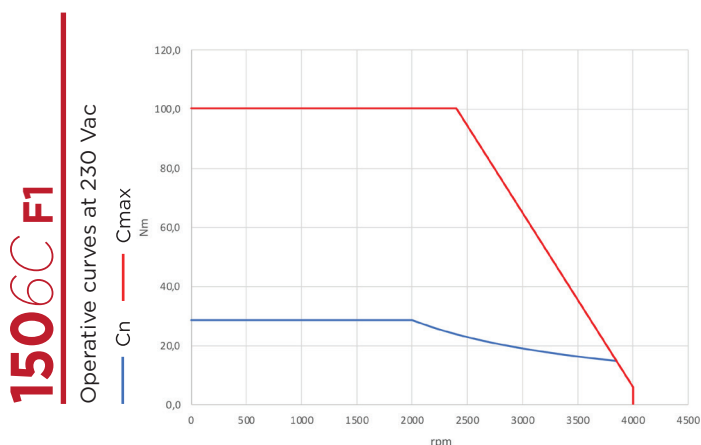

EXTERNAL DIMENSIONS 150

G2/H2 connection

Model	Feedback type	L [mm]	L with brake [mm]	Z [mm]	Z with brake [mm]
6A	A1-M1-M2-R1	205.0	250.0	126.5	126.5
6B	A1-M1-M2-R1	250.0	295.0	171.0	171.0
6C	A1-M1-M2-R1	295.0	340.0	216.5	216.5

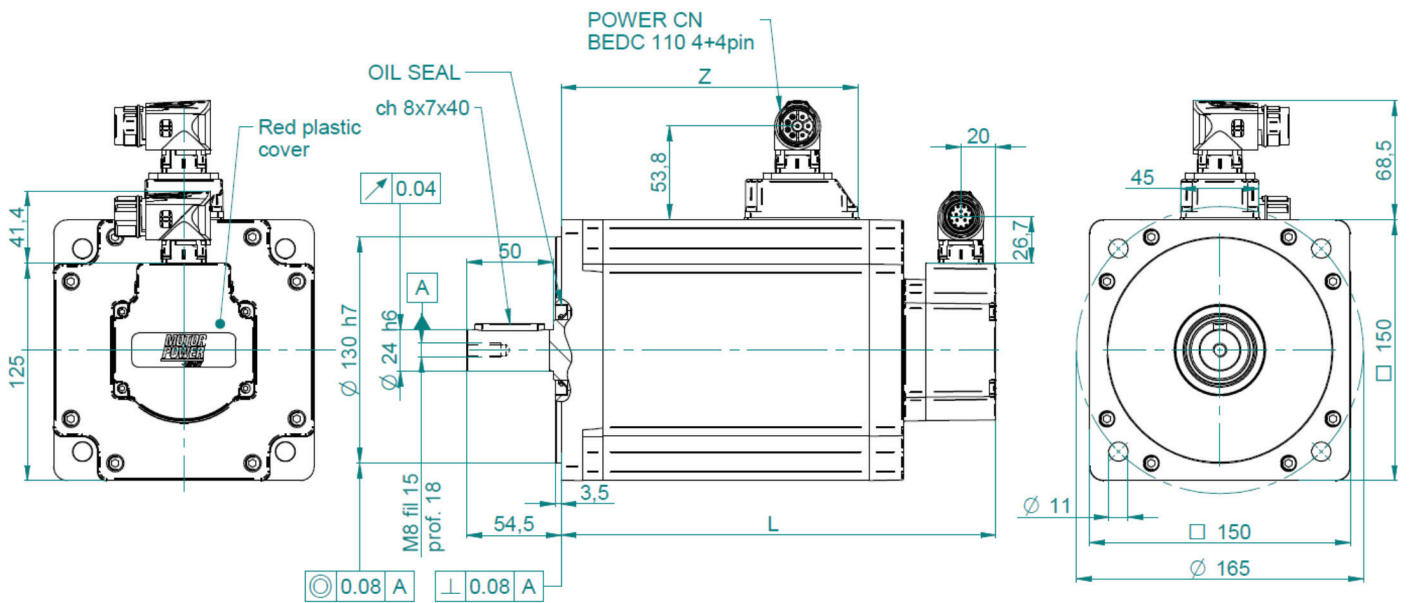

G9/H9 connection

Model	Feedback type	L [mm]	L with brake [mm]	Z [mm]	Z with brake [mm]
6B	A1-M1-M2-R1	250.0	295.0	171.0	171.0
6C	A1-M1-M2-R1	295.0	340.0	216.5	216.5

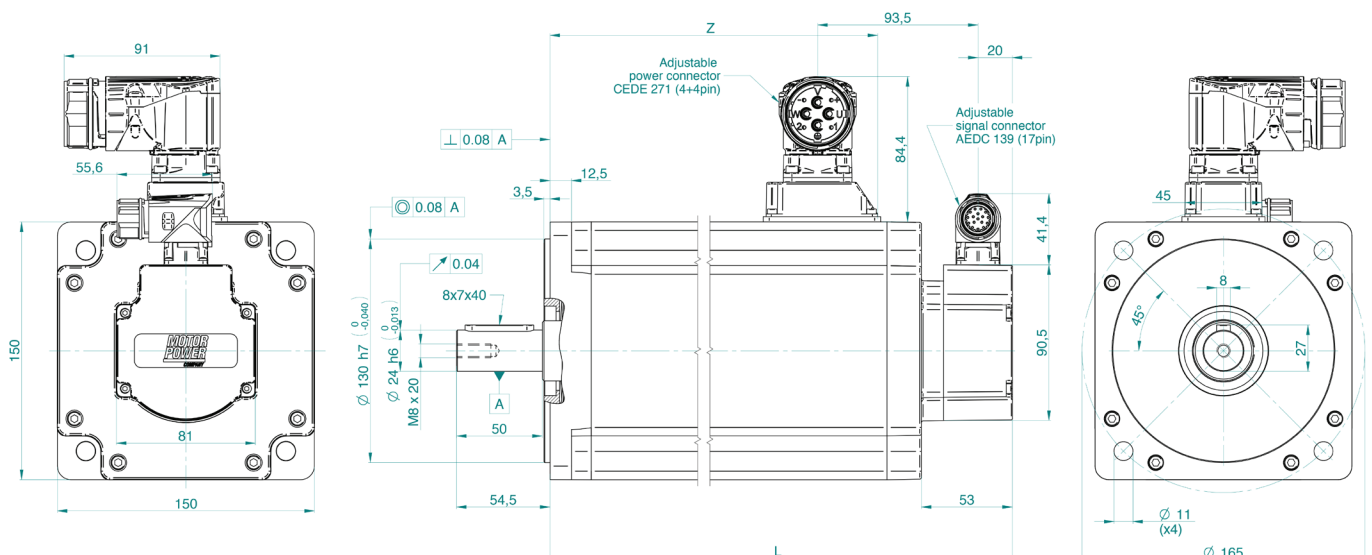

WWW.P

TETRA
COMPACT 4

180

180 7A RATINGS and SPECIFICATION

	230/400 Vac
TYPE OF WINDING	26

ELECTRICAL DATA

Continuous stall torque (*)	M_o	[Nm]	9.55
Peak torque	M_{Max}	[Nm]	28.65
Nominal torque	M_n	[Nm]	6.37
Nominal power	P_n	[W]	2000
Continuous stall current	I_o	[Arms]	8.75
Maximum current	I_{Max}	[Arms]	35.5
Nominal current	I_n	[Arms]	6.27
Nominal working speed	n_N	[rpm]	3000
Maximum working speed	n_{Max}	[rpm]	4000
Torque constant	K_t	[Nm/Arms]	1.09
Voltage constant	$K_{e\ u-v}$	[Vrms/krpm]	66
Winding resistance @ 20 °C	R_{u-v}	[Ohm]	0.590
Winding inductance	$L_{q\ u-v}$	[mH]	6.7
Electrical time constant	T_e	[ms]	11.4
Thermal resistance	R_{th}	[°C/W]	-
Mechanical time constant (a)	T_m	[ms]	1.25
Rotor inertia without holding brake	J	[kg·cm ²]	25.22
Rotor inertia with holding brake	J	[kg·cm ²]	30.39
Mass without holding brake	m	[kg]	14.64
Mass with holding brake	m	[kg]	19.64
Max. axial shaft load 3000 / 6000 rpm	SL_a	[N]	500
Max. radial shaft load 3000 / 6000 rpm	SL_r	[N]	2300

Rated output with 550 x 550 x 20 mm aluminium heat sink flange. Derating must be considered if the oil seal is applied - IP 54 standard shaft bushing.
 (*) without brake. (a) without brake and without feedback.

TORQUE/SPEED CHARTS

Operative temperature -20 ÷ +40 °C

Any specifications are subjected to change without notice.
 All rights reserved Motor Power Company®

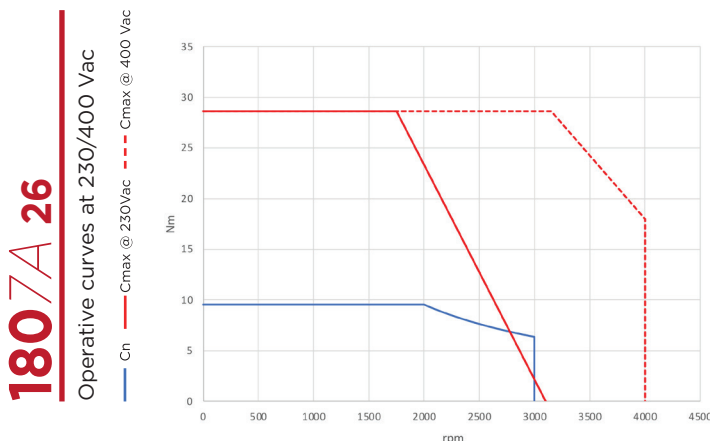

180 7C RATINGS and SPECIFICATION

	TYPE OF WINDING	230/400 Vac	
			15A
ELECTRICAL DATA			
Continuous stall torque (*)	M_o	[Nm]	16.7
Peak torque	M_{Max}	[Nm]	50.3
Nominal torque	M_n	[Nm]	11.14
Nominal power	P_n	[W]	3500
Continuous stall current	I_o	[Arms]	16.83
Maximum current	I_{Max}	[Arms]	61.0
Nominal current	I_n	[Arms]	12.07
Nominal working speed	n_N	[rpm]	3000
Maximum working speed	n_{Max}	[rpm]	4000
Torque constant	K_t	[Nm/Arms]	0.99
Voltage constant	$K_{e\ u-v}$	[Vrms/krpm]	60
Winding resistance @ 20 °C	R_{u-v}	[Ohm]	0.136
Winding inductance	$L_{q\ u-v}$	[mH]	2.48
Electrical time constant	T_e	[ms]	18.2
Thermal resistance	R_{th}	[°C/W]	-
Mechanical time constant (e)	T_m	[ms]	0.62
Rotor inertia without holding brake	J	[kg·cm ²]	44.81
Rotor inertia with holding brake	J	[kg·cm ²]	46.60
Mass without holding brake	m	[kg]	20.0
Mass with holding brake	m	[kg]	25.0
Max. axial shaft load 3000 / 6000 rpm	SL_a	[N]	500
Max. radial shaft load 3000 / 6000 rpm	SL_r	[N]	2300

Rated output with 550 x 550 x 20 mm aluminium heat sink flange. Derating must be considered if the oil seal is applied - IP 54 standard shaft bushing.
 (*) without brake. (a) without brake and without feedback.

TORQUE/SPEED CHARTS

Operative temperature -20 ÷ +40 °C

Any specifications are subjected to change without notice.
 All rights reserved Motor Power Company®

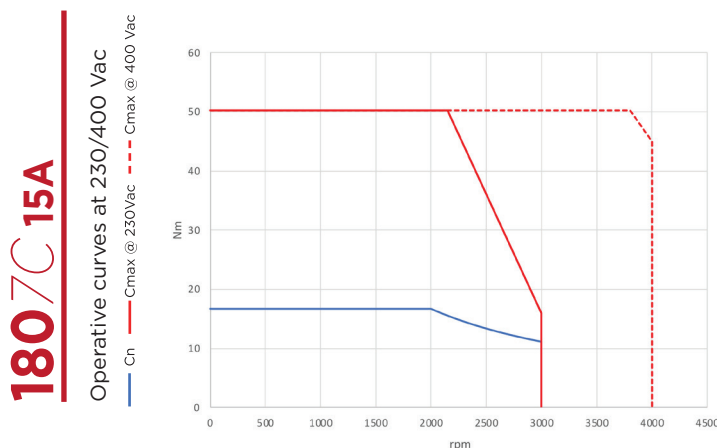

180 7D RATINGS and SPECIFICATION

	TYPE OF WINDING	230/400 Vac	
		G1	
ELECTRICAL DATA			
Continuous stall torque (*)	M_o	[Nm]	28.65
Peak torque	M_{Max}	[Nm]	71.62
Nominal torque	M_n	[Nm]	28.65
Nominal power	P_n	[W]	4500
Continuous stall current	I_o	[Arms]	19.68
Maximum current	I_{Max}	[Arms]	61.0
Nominal current	I_n	[Arms]	22.8
Nominal working speed	n_N	[rpm]	1500
Maximum working speed	n_{Max}	[rpm]	4000
Torque constant	K_t	[Nm/Arms]	1.46
Voltage constant	$K_{e\ u-v}$	[Vrms/krpm]	88
Winding resistance @ 20 °C	R_{u-v}	[Ohm]	0.169
Winding inductance	$L_{q\ u-v}$	[mH]	3.46
Electrical time constant	T_e	[ms]	20.4
Thermal resistance	R_{th}	[°C/W]	-
Mechanical time constant (a)	T_m	[ms]	0.52
Rotor inertia without holding brake	J	[kg·cm ²]	64.99
Rotor inertia with holding brake	J	[kg·cm ²]	66.78
Mass without holding brake	m	[kg]	25.69
Mass with holding brake	m	[kg]	31.40
Max. axial shaft load 3000 / 6000 rpm	SL_a	[N]	500
Max. radial shaft load 3000 / 6000 rpm	SL_r	[N]	2300

Rated output with 550 x 550 x 20 mm aluminium heat sink flange. Derating must be considered if the oil seal is applied - IP 54 standard shaft bushing.
 (*) without brake. (a) without brake and without feedback.

TORQUE/SPEED CHARTS

Operative temperature -20 ÷ +40 °C

Any specifications are subjected to change without notice.
 All rights reserved Motor Power Company®

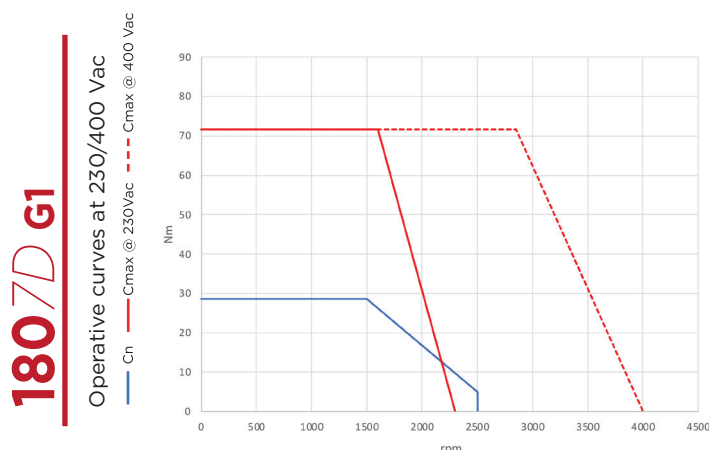

180 7E RATINGS and SPECIFICATION

	TYPE OF WINDING	230/400 Vac	
		G5	
ELECTRICAL DATA			
Continuous stall torque (*)	M_o	[Nm]	35
Peak torque	M_{Max}	[Nm]	87.53
Nominal torque	M_n	[Nm]	35
Nominal power	P_n	[W]	5500
Continuous stall current	I_o	[Arms]	25.05
Maximum current	I_{Max}	[Arms]	74.2
Nominal current	I_n	[Arms]	28.8
Nominal working speed	n_N	[rpm]	1500
Maximum working speed	n_{Max}	[rpm]	4000
Torque constant	K_t	[Nm/Arms]	1.4
Voltage constant	$K_{e\ u-v}$	[Vrms/krpm]	84.5
Winding resistance @ 20 °C	R_{u-v}	[Ohm]	0.093
Winding inductance	$L_{q\ u-v}$	[mH]	2.08
Electrical time constant	Te	[ms]	22.4
Thermal resistance	R_{th}	[°C/W]	-
Mechanical time constant (a)	T_m	[ms]	0.49
Rotor inertia without holding brake	J	[kg·cm ²]	102.46
Rotor inertia with holding brake	J	[kg·cm ²]	104.30
Mass without holding brake	m	[kg]	34.15
Mass with holding brake	m	[kg]	39.09
Max. axial shaft load 3000 / 6000 rpm	SL_a	[N]	500
Max. radial shaft load 3000 / 6000 rpm	SL_r	[N]	2300

Rated output with 550 x 550 x 20 mm aluminium heat sink flange. Derating must be considered if the oil seal is applied - IP 54 standard shaft bushing.
 (*) without brake. (a) without brake and without feedback.

TORQUE/SPEED CHARTS

Operative temperature -20 ÷ +40 °C

Any specifications are subjected to change without notice.
 All rights reserved Motor Power Company®

180 7E G5
 Operative curves at 230/400 Vac
 — C_n — $C_{max@230Vac}$ - - - $C_{max@400Vac}$

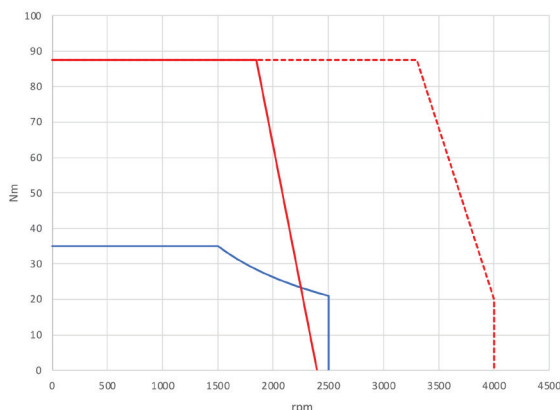

180 7F RATINGS and SPECIFICATION

	230/400 Vac
TYPE OF WINDING	69

ELECTRICAL DATA

Continuous stall torque (*)	M_0	[Nm]	47.75
Peak torque	M_{Max}	[Nm]	119.37
Nominal torque	M_n	[Nm]	47.75
Nominal power	P_n	[W]	7500
Continuous stall current	I_0	[Arms]	36.08
Maximum current	I_{Max}	[Arms]	106.9
Nominal current	I_n	[Arms]	41.5
Nominal working speed	n_N	[rpm]	1500
Maximum working speed	n_{Max}	[rpm]	4000
Torque constant	K_t	[Nm/Arms]	1.32
Voltage constant	$K_{e\ u-v}$	[Vrms/krpm]	80
Winding resistance @ 20 °C	R_{u-v}	[Ohm]	0.053
Winding inductance	$L_{q\ u-v}$	[mH]	1.34
Electrical time constant	T_e	[ms]	25.3
Thermal resistance	R_{th}	[°C/W]	-
Mechanical time constant (a)	T_m	[ms]	0.43
Rotor inertia without holding brake	J	[kg·cm ²]	140.62
Rotor inertia with holding brake	J	[kg·cm ²]	142.66
Mass without holding brake	m	[kg]	44.52
Mass with holding brake	m	[kg]	49.59
Max. axial shaft load 3000 / 6000 rpm	SL_a	[N]	500
Max. radial shaft load 3000 / 6000 rpm	SL_r	[N]	2300

Rated output with 550 x 550 x 20 mm aluminium heat sink flange. Derating must be considered if the oil seal is applied - IP 54 standard shaft bushing.
 (*) without brake. (a) without brake and without feedback.

TORQUE/SPEED CHARTS

Operative temperature -20 ÷ +40 °C

Any specifications are subjected to change without notice.
 All rights reserved Motor Power Company®

180 7F 69
 Operative curves at 230/400 Vac
 — C_n — C_{max} @ 230Vac — C_{max} @ 400 Vac

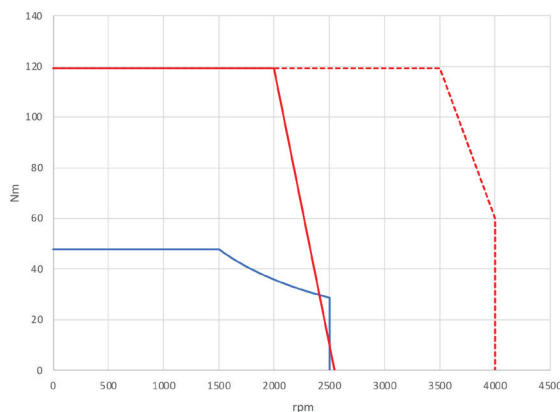

180 EXTERNAL DIMENSIONS

G2/H2 connection

Model	Feedback type	L [mm]	L with brake [mm]	Z [mm]	Z with brake [mm]
7A	A1-M1-M2-R1	183.0	230.0	103.0	103.0
7C	A1-M1-M2-R1	216.0	251.0	136.0	136.0
7D	A1-M1-M2-R1	249.0	284.0	169.0	169.0
7E	A1-M1-M2-R1	293.0	328.0	213.0	213.0
7F	A1-M1-M2-R1	356.0	391.0	276.0	276.0

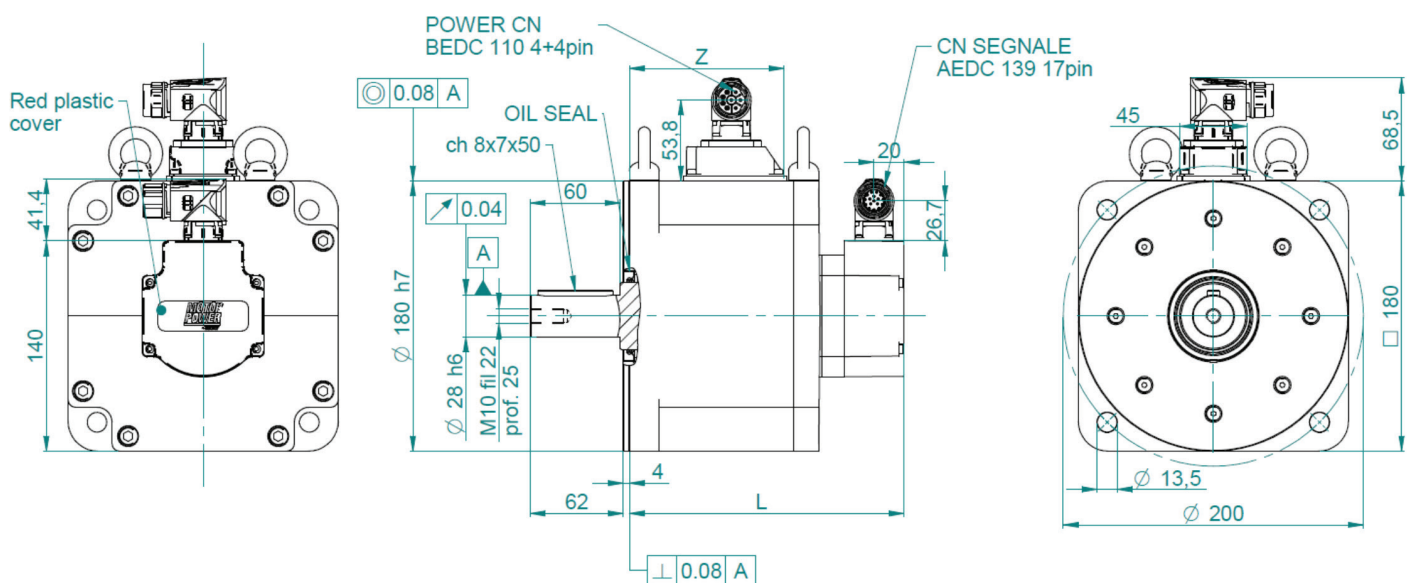

TC4 NOTE

feedback

TC4 Resolver

		R1	
<i>Motor size</i>		TC4 60 - TC4 80	TC4 100 - TC4 130 - TC4 150 - TC4 180
Nominal voltage	Vrms	7±5%	7±5%
Nominal current	mA	50	50
Phase shift		+3°	-5°
Minimum sin amplitude	mVrms	20	20
Frequency	kHz	10	10
Poles number		2	2
Tranformer ratio		0.5 ± 5%	0.5 ± 5%
Input impedance	Ohm	130 + j280	110+j140
Output impedance	Ohm	425 + j755	130+j240
System accuracy		± 10'	± 10'
Rotor inertia	kg cm2	0.03	0.1

TC4 Encoder

	M1	M2	M3
<i>Type</i>	M-CODER IH INCREMENTAL WITH HALL SENSOR ENCODER	M-CODER ST ABSOLUTE ENCODER	M-CODER STBL ABSOLUTE ENCODER
Protocol/Interface	Line Driver A/B/Z - U/V/W	RS 485 2,5 Mbit	Biss Line 2 Wire
Resolution	2-5000 ppr	23 bit	23 bit
Accuracy	+/- 250''	+/- 250''	+/- 250''
Working temperature	-40 °C ... +125 °C	-40 °C ... +125 °C	-40 °C ... +125 °C
Working speed	<12000 rpm	<12000 rpm	<12000 rpm
Max acceleration	100.000 rad/s ²	100.000 rad/s ²	100.000 rad/s ²
Inertia	5.6 × 10 ⁻⁵ kg*cm ²	5.6 × 10 ⁻⁵ kg*cm ²	5.6 × 10 ⁻⁵ kg*cm ²
Weigth	20 g	20 g	20 g
Main supply voltage	5 - 12 V	5 - 12 V	5 - 12 V
Current consumption	100mA (Max)	100mA (Max)	100mA (Max)
External battery voltage	-	-	-
External battery current consumption	-	-	-
Note	Condition monitoring option	Condition monitoring option	Condition monitoring option

	A5	A6	A15
<i>Type</i>	HIPERFACE SAFETY DSL SINGLETURN 20 BIT ENCODER	HIPERFACE SAFETY DSL MULTITURN 20 BIT ENCODER	HIPERFACE SAFETY DSL SINGLETURN 24 BIT ENCODER
Protocol/Interface	HIPERFACE DSL®	HIPERFACE DSL®	HIPERFACE DSL®
Resolution	20 bit	20 bit	24 bit
N° absolute multiturn steps	-	4096 (12 bit)	-
Accuracy	+/- 100''	+/- 100''	+/- 25''
Working temperature	-20 °C ... +115 °C	-20 °C ... +115 °C	-40 °C ... +115 °C
Working speed	<12000 rpm	<12000 rpm	<9000 rpm
Max acceleration	250.000 rad/s ²	250.000 rad/s ²	250.000 rad/s ²
Inertia	5 gcm ²	5 gcm ²	5 gcm ²
Weigth	100 g	100 g	100 g
Main supply voltage	7 - 12 V	7 - 12 V	7 - 12 V
Current consumption	150 mA (max)	150 mA (max)	150 mA (max)
External battery voltage	-	-	-
External battery current consumption	-	-	-
Note		Mechanical multiturn	

Safety function: SIL2 (IEC 61508) PL.d (EN ISO 13849)

Safety function: SIL2 (IEC 61508) PL.d (EN ISO 13849)

Safety function: SIL2 (IEC 61508) PL.d (EN ISO 13849-1:2015)

<i>Type</i>	A1	A3	A4
	HIPERFACE ABSOLUTE MULTITURN ENCODER	HIPERFACE DSL ABSOLUTE SINGLETURN ENCODER	HIPERFACE DSL ABSOLUTE MULTITURN ENCODER
Protocol/Interface	HIPERFACE®	HIPERFACE DSL®	HIPERFACE DSL®
Resolution	128 line	20 bit	20 bit
N° absolute multiturn steps	4096 (12 bit)	-	4096 (12 bit)
Accuracy	4096 (12 bit)	+/- 100''	+/- 100''
Working temperature	-20 °C ... +100 °C	-20 °C ... +115 °C	-20 °C ... +115 °C
Working speed	<9000 rpm	<12000 rpm	<12000 rpm
Max acceleration	500.000 rad/s ²	500.000 rad/s ²	500.000 rad/s ²
Inertia	4,5 gcm ²	4,5 gcm ²	4,5 gcm ²
Weigth	70 g	100 g	100 g
Main supply voltage	7 - 12 V	7 - 12 V	7 - 12 V
Current consumption	60 mA (withoul Load)	150 mA (max)	150 mA (max)
External battery voltage	-	-	-
External battery current consumption	-	-	-
Note	Mechanical multiturn		Mechanical multiturn

<i>Type</i>	A16	A22	A23
	HIPERFACE SAFETY DSL MULTITURN 24 BIT ENCODER	ENCODER SAFETY ENDAT 3 SINGLETURN 19 BIT ENCODER	ENCODER SAFETY ENDAT 3 MULTITURN 19 BIT ENCODER
Protocol/Interface	HIPERFACE DSL®	ENDAT 3®	ENDAT 3®
Resolution	24 bit	19 bit	19 bit
N° absolute multiturn steps	4096 (12 bit)	-	4096 (12 bit)
Accuracy	+/- 25''	+/- 120''	+/- 120''
Working temperature	-40 °C ... +115 °C	-40 °C ... +110 °C	-40 °C ... +110 °C
Working speed	<9000 rpm	<15000 rpm	<12000 rpm
Max acceleration	250.000 rad/s ²	≤ 1 · 10 ⁵ rad/s ²	≤ 1 · 10 ⁵ rad/s ²
Inertia	5 gcm ²	0.2 · 10 ⁻⁶ kgm ²	0.2 · 10 ⁻⁶ kg m ²
Weigth	100 g	40 g	40 g
Main supply voltage	7 - 12 V	3,6 - 14 V	3,6 - 14 V
Current consumption	150 mA (max)	At 5 V: 95 mA (without load)	At 5 V: 115 mA (without load)
External battery voltage	-	-	-
External battery current consumption	-	-	-
Note	Mechanical multiturn		Mechanical multiturn

Safety function: SIL2 (IEC 61508) PL.d (EN ISO 13849-1:2015)

Safety function: SIL3 (IEC 61508) PL.e

Safety function: SIL3 (IEC 61508) PL.e

N1

Type A-format 24-bit absolute multi-turn (with battery) and absolute single turn encoder (without battery). Encoder N1 available for models 40-60-80

Protocol/Interface	A-FORMAT RS 485 2,5-16Mbits
Resolution	24 bit
N° absolute multiturn steps	65536 (16 bit)
Accuracy	+/- 90"
Working temperature	-20 °C ... +105 °C
Working speed	<8000 rpm
Max acceleration	$1.0 \times 10^5 \text{ rad/s}^2$
Inertia	$2.6 \times 10^{-9} \text{ kg} \cdot \text{m}^2$
Weigth	13 g
Main supply voltage	5 +/- 10% V
Current consumption	80uA typical 110 uA max
External battery voltage	3,6 +/-10% V
External battery current consumption	55uA typical 110 uA max

Note Feedback N1 is provided as singleturn device.
With the multiturn usage battery must be applied. Please reach out our application team for assistance with the electric scheme connection.

specifications

TC4 Brake features

MOTOR SIZE		40	60	80	100	130	150	180
Operating motor temperature	[°C]	-20 ÷ 120						
External ambient temperature	[°C]	-20 ÷ 40						
Standard brake duty	-	Stationary						
Minimum dry static torque (-20 ÷ 120 °C)	[Nm]	0.32	1.3	2.5	6.5	9.6	32	48
Nominal operating voltage (± 10 %)	[Vdc]	24						
Power consumption at 20 °C (± 7 %)	[W]	4.35	11.2	10.2	10.4	19.7	TBD	49.6
Release time	[ms]	22	58	46	49	71	TBD	120
Brake release time (pull-in)	[ms]	77	25	58	30	39	TBD	37
Maximum backlash	[deg]	1.2						

TC4 Wiring motor connection

Connectors with G2 connection

Power connector		Feedback connector			
Pin	Function	Pin	A1	N1	R1
1	Phase U	1	-	-	-
2	PE	2	-	-	-
3	Phase W	3	0V	0V	-
4	Phase V	4	7-12V	+ 5V	-
A	Brake + (#)	5	/sin	data -	/sin
B	Brake - (#)	6	sin	data +	sin
C	PT 1000 +	7	/data	-	/ref
D	PT 1000 -	8	data	-	ref
		9	-	-	-
		10	shield	shield	shield
		11	/cos	-	/cos
		12	cos	-	cos
		13	-	-	-
		14	-	-	-
		15	-	-	-
		16	-	-	-
		17	-	-	-

(#) Optional

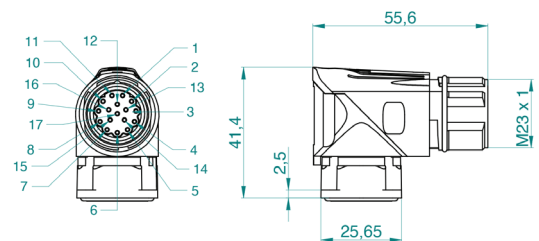
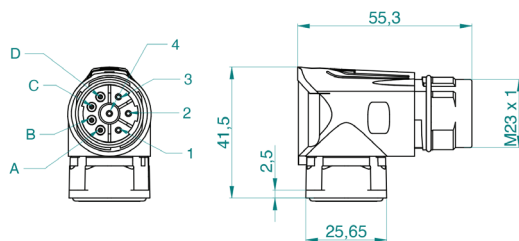

Connectors with H2 connection

Power connector		Feedback connector			
Pin	Function	Pin	A1	N1	R1
1	Phase U	1	-	-	-
2	PE	2	-	-	-
3	Phase W	3	0V	0V	-
4	Phase V	4	7-12V	+ 5V	-
A	Brake + (#)	5	/sin	data -	/sin
B	Brake - (#)	6	sin	data +	sin
C	-	7	/data	-	/ref
D	-	8	data	-	ref
		9	-	-	-
		10	shield	shield	shield
		11	/cos	-	/cos
		12	cos	-	cos
		13	-	-	-
		14	-	-	-
		15	-	-	-
		16	PT 1000 +	PT 1000 +	PT 1000 +
		17	PT 1000 -	PT 1000 -	PT 1000 -

(#) Optional

One cable connector with C21 connection

Pin	Function
1	Phase U
2	PE
3	Phase W
4	Phase V
A	Data +
B	Data -
C	Brake +
D	Brake -

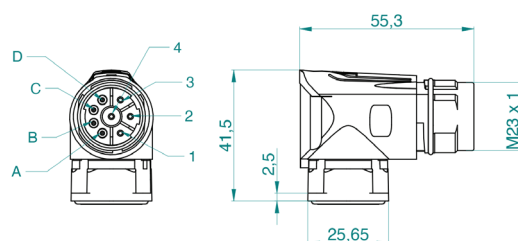
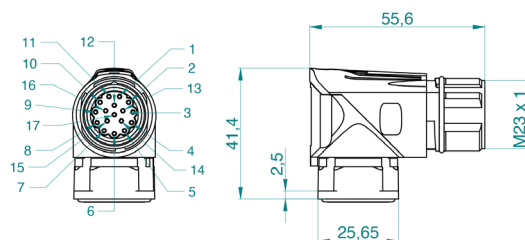

TC4 Wiring motor connection

Connectors with D0 connection (9 pins, only for models 40-60-80)

Power connector		Feedback connector			
Pin	Function	Pin	A1	N1	R1
1	Phase U	1	data +	data +	-
2	Phase V	2	+ sin	-	-
3	Phase W	3	Refsin	-	-
4	PE	4	data -	data -	-
5	PT 1000 + / brake + ^(#)	5	+ cos	-	-
6	PT 1000 - / brake - ^(#)	6	Refcos	-	-
		7	8V / us	+ 5V	-
		8	0V	0V	-
		9	shield	shield	-

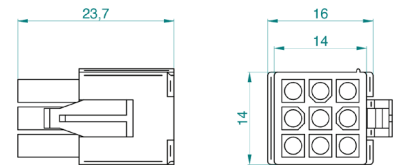
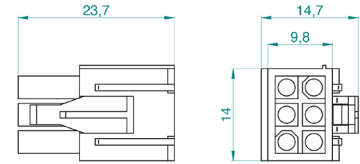

(#) Optional

Connectors with D2 connection (15 pins, only for models 40-60-80)

Power connector		Feedback connector	
Pin	Function	Pin	M1
1	Phase U	1	Ch A
2	Phase V	2	Ch/A
3	Phase W	3	Ch B
4	PE	4	Ch/B
5	PT 1000 + / brake + ^(#)	5	Ch Z
6	PT 1000 - / brake - ^(#)	6	Ch/Z
		7	Hall U
		8	Hall/U
		9	Hall V
		10	Hall/V
		11	Hall W
		12	Hall/W
		13	5 Vdc
		14	0 Vdc
		15	Shield

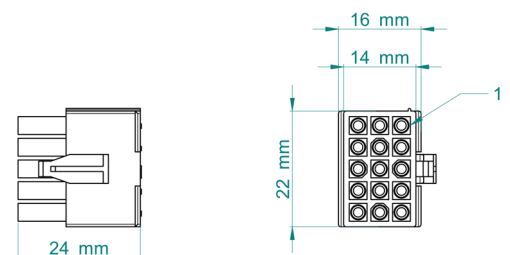
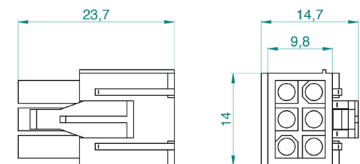

(#) Optional

Motor Power Company
www.motorpowerco.com
info@motorpowerco.it

All rights reserved.
Complete or partial reproduction
is not allowed without our permission.

All technical data in this catalog
may be changed without prior notice.



**Motor Power
Company s.r.l.**

Via Leonardo Da Vinci, 4
42024 Castelnovo Sotto
Reggio Emilia (Italy)
Tel. +39 0522 682710
Fax +39 0522 683552
info@motorpowerco.it

**Motor Power Company
(Taicang) Motion Co. Ltd.**

Workshop 7, Shiny Science Park No. 111
215400 Taicang, P.R.China
Tel + 86 512 33337978
Fax +86 512 53207871
infoasia@motorpowerco.com



motorpowerco.com

